

Linköping studies in science and technology.
Dissertations, No. 1955

OPTICAL DOCUMENT SECURITY
MEASUREMENT, CHARACTERIZATION AND VISUALIZATION
– IN THE LIGHT OF VISUAL EVALUATION

MIKAEL LINDSTRAND



Division of Media and Information Technology
Department of Science and Technology
Linköping University, SE-601 74 Norrköping, Sweden
Stockholm 2018

**Optical Document Security: Measurement, Characterization and
Visualization — in the Light of Visual Evaluation**

Copyright © 2018 Mikael Lindstrand (unless otherwise noted)

*Division of Media and Information Technology
Department of Science and Technology
Campus Norrköping, Linköping University
SE-601 74 Norrköping
Sweden*

ISBN: 978-91-7685-206-4

ISSN: 0345-7524

Printed in Sweden by LiU-Tryck, Linköping, 2018

Bringing a surface into a convex shape facilitates inspecting of e.g. gloss characteristics.
(Figure 2, page 12)

The interactive visualization interface introduced facilitates pairwise comparison of gloss characteristics of a surface.
(Figure 8, page 32)

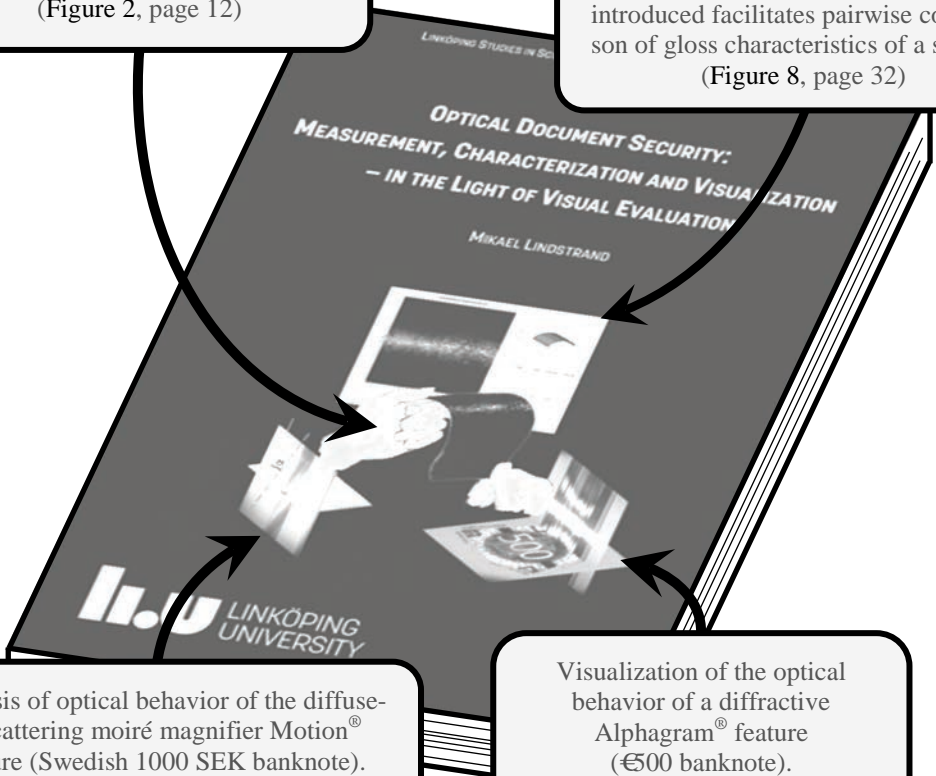

Analysis of optical behavior of the diffusely scattering moiré magnifier Motion® feature (Swedish 1000 SEK banknote).
(Figure 7, page 31)

Visualization of the optical behavior of a diffractive Alphagram® feature (€500 banknote).
(c.f. Figure 5, page 28)

Abstract

Documents of high value, such as passports, tickets and banknotes, facilitate means for authentication. Authentication processes aim at mitigating counterfeit “passable products”. The arsenal of “security features” in the business is abundant but an effective and reliable counterfeit mitigating system need an architectural approach rather than either relying on one feature only, or vaguely motivated aggregated security features.

Optically variable device (OVD) is a concept in the industry, including cost-efficient and unique authentication functionality. OVD based features may serve as the main counterfeit mitigating functionality, as in banknotes. For higher value documents, such as passports, security architectural design may include multimodal (combined) features in which OVD is one characterizing and necessary aspect. Thereby a successful counterfeit need not only to simulate (“hack”) electronic based security features, such as radio frequency based identifier combined with public key infrastructure based cryptography (PKI) but also simulate OVD functionality. Combined feature authentication, based e.g. on PKI and OVD that relies on principally different physics and hence technology competences is of especial interest. Well-architected and implemented, such multimodal counterfeit mitigating systems are effective to the degree that producing passable products requiring more resources than potentially illegitimately gained by the counterfeiter. Irrespective of level of ambition and efforts spent on counterfeit mitigation, OVD remains critically important as a security concept. One feature of OVD is the possibility to include a human inspector in the authentication procedure. Including such “man-in-the-loop” reduces the risk of successful and unnoticed simulations of algorithms, such as PKI. One challenge of OVD is a lack of standards or even measurements characterizing the significant aspects influencing a human based inspection.

This thesis introduces a system able to measure, characterize and visualize the significant aspects influencing a human based inspection of OVD features. The contribution includes the development of a multidimensional and high-dynamic range (HDR) color measurement system of spatial and angular resolution. The capturing of HDR images is particularly demanding for certain high contrast OVD features and require innovative algorithms to achieve the necessary high contrast sensitivity function of the imaging sensor.

Representing the significant aspects influencing a human based inspection of OVD requires a considerable amount of data. The development of an appropriate information protocol is therefore of importance, to facilitate further analysis, data processing and visualization. The information protocol transforming the measurement data into characterizing information is a second significant achievement of the presented work in this thesis.

To prove the applicability measurements, visualizations and statistically based analyses have been developed for a selection of previously unsolved problems, as defined by senior scientists and representatives of central banks. Characterization and measurements of the degree to which OVD deteriorate with circulation is one such problem. One particular benefit of the implemented suggested solution is the charac-

terization and measurement aim at aspects influencing human based (“first line”) inspection. The principally difference in the problems treated indicates the generality of the system, which is a third significant project achievement.

The system developed achieves the accuracy and precision including a resolution, dynamic range and contrast sensitivity function required for a technology independent standard protocol of “optical document security” OVDs. These abilities facilitate the definition and verification of program of requirements for the development of new security documents. Adding also the capability of interlinking first, second and third line inspection based characterizations may prove a particular valuable combination, which is a fourth significant project achievement.

The information content (Entropy) of characterized OVDs and OVD production limitations in combination opens for OVD based novel applications of “physically unclonable functions” (PUF). This is of significance as it would generalize the established OVDs to facilitate multimodal verification, including PUF verification. The OVDs would thereby transform into a combined PUF first line inspection facilitating security feature.

Populärvetenskaplig sammanfattning

För värdefulla dokument, till exempel pass, biljetter och sedlar, är det viktigt att kunna skilja äkta från falska. Enkla effektiva metoder att avgöra äkthet ökar chansen att förfalskningar upptäcks. Begreppet ”passerbar produkt” används av säkerhetspolisen i USA för förfalskade produkter som accepteras av (har passerat) personer i allmänhet eller lekmän, t ex kassapersonal. Syftet med ”säkerhetsfunktioner” och säkerhetssystem är att underlätta bedömningen om ett dokument är äkta eller inte. Svårigheten är att göra effektiva system, där målet är att alla förfalskningar upptäcks, alla äkta dokument accepteras, är enkelt att använda och har låga kostnader. Säkerhetssystem, där varje delfunktion är motiverad och har ett väldefinierat syfte i samverkan med övriga funktioner (”god säkerhetsarkitektur”), har förutsättningar att vara effektiva. Att arbeta enligt god säkerhetsarkitektur är dock krävande. Enklare är att inkludera ett antal enskilda säkerhetsfunktioner som förhoppningsvis delvis kompletterar varandra. Det förenklade arbetssättet är inte ovanligt, men leder undantagslöst till mindre effektiva säkerhetssystem.

”Optically variable devices” (OVD) (ung. optiskt variabelt material) är ett etablerat samlingsnamn i branschen för ytor som ändrar utseendet, när ytan lutar i olika vinklar. Vissa OVD:er är svåra att förfalska så att kopian liknar originalet, även med tillgång till omfattande resurser. Dessutom, originalet behöver inte vara dyrt att producera. Den typen av OVD:er möjliggör ett kostnadseffektivt sätt att skilja äkta från falska dokument. Därför är ofta OVD:er den huvudsakliga funktionen i säkerhetssystem, t ex som för sedlar. Mer värdefulla dokument, som passhandlingar, kräver högre grad av säkerhet. Funktioner som elektronisk krypton, baserat t ex på infrastruktur för ”publika nycklar” (public key infrastructure, ”PKI”), kan uppnå mycket hög teoretisk säkerhet. Men eftersom varje funktion löper risk att förfalskas (”hacks”) är det riskfyllt att förlita sig på endast en teknologi. Ett sådant säkerhetssystem skulle bli onödigt sårbart. Dessutom finns en uppenbar risk att en hackad elektronisk funktion förbli oupptäckt, vilket leder till än mer omfattande skador.

En mer effektiv *säkerhetsarkitektur* baseras istället på ett väl underbyggt val av olika *typer* av säkerhetsfunktioner för att skilja äkta från falskt. Där är OVD ofta en av dessa funktioner. Kopiering kräver då djupa kunskaper i samtliga discipliner (motsvarande valen av säkerhetsfunktionstyperna) vilket kräver avsevärda resurser. Systemet blir därför ett mer effektivt hinder för kopiering. Dessutom ger OVD möjlighet till människa-i-verifieringsprocessen vilket bedöms minska risken för att förfalskningar förblir oupptäckta.

De beskrivna fördelarna med OVD:er gör att de sannolikt även fortsättningsvis kommer att vara en viktig komponent antingen som enskild och huvudsaklig säkerhetsfunktion eller som del i ett sammansatt säkerhetssystem, för att verifiera säkerhetsdokument. En svårighet under utveckling och produktion av OVD:er är att det saknas standarder eller ens mätetal för mest väsentliga egenskaperna, det vill säga utseendet och det ”optiska beteendet”.

I avhandlingen introduceras system för att mäta, karaktärisera och visualisera de väsentliga egenskaperna som påverkar en visuell inspektion av OVD:er. Utvecklingen

av ett multidimensionellt avbildande mätsystem med stort dynamiskt omfång och vinkelupplösning är ett av projektets viktiga resultat. Att mäta OVD:er med stort färgomfång och hög kontrast är speciellt svårt och kräver utveckling av innovativa algoritmer för sensorn (kameran), för att uppnå tillräckligt hög kontrastkänslighet i mätsystemet.

För att beskriva de viktigaste egenskaperna som påverkar en visuell inspektion av OVD:er, krävs information av olika karaktär baserad på stora datamängder. Ett informationsprotokoll är en struktur som beskriver hur mätningens stora datamängder omformas till valda kategorier av information. Ett effektivt sådant protokoll är viktigt också för att underlätta vidare analys, bearbetning och visualisering, speciellt då informationen är av olika karaktär och är baserad på stora datamängder. Därför är det utvecklade informationsprotokollet ett andra av avhandlingens viktiga resultat.

För att påvisa både konkret praktisk nytta och stor potential har lösningar för problem inom principiellt skilda områden presenterats. En rad mätetal, visualiseringar och statistiska analyser har utvecklats för problem som beskrivs som uttalade utmaningar av såväl centralbanker som etablerade forskare i säkerhetsdokumentbranschen. Karaktärisering av och mått på hur utseendet hos OVD:er förändras (försämras) genom cirkulation (förslitning) är ett sådant problem. De behandlade exempelproblemens stora principiella skillnader visar på systemets generalitet, vilket är ett tredje av avhandlingens viktiga resultat.

Det utvecklade systemet har en tillräckligt god noggrannhet och kontrastkänslighet för att utveckla en användbar teknologioberoende standard för OVD:er.

Dessa förmågor hos systemet kan få avgörande betydelse vid formulering och verifiering av kravspecifikation under utveckling av nya säkerhetsdokument. Att systemets karaktärisering även ger helt nya möjligheter till jämförelser av visuell inspektion ("första linjens inspektion"), med inspektion med hjälp av automatiska mätsystem ("andra linjen"), och avancerad kriminalteknisk inspektion ("tredje linjen"), kan visa sig vara en speciellt värdefull kombination.

Systemets höga prestanda i kombination med fysikaliska begränsningar i tillverkningsprocesser av OVD:er (det finns inte två identiskt lika OVD:er), ger möjligheter till säkerhetsmaterial som inte är möjliga att kopiera (eng. "physically unclonable devices"). En icke-kopierbar funktion är ett centralt begrepp i säker kommunikation och är mycket eftertraktad men svår att realisera. Denna nya potentiella tillämpning görs sannolik bland annat genom jämförelser med etablerade ansatser till icke-kopierbara funktioner baserad på annan teknologi.

Acknowledgment

Given that I had to spend more than two decades, yes!, as an industrial PhD student to fulfill this project, the following wording may be justified without even a smallest risk of sounding pompous and should be read without irony: This endurance endeavor would not have been possible without the help from others.

First of all I would like to thank my two supervisors at the university: Björn Kruse, for always being positive, friendly and for trusting me to have the freedom of trying out my ideas. After finalizing the Licentiate thesis (2002), Björn later retired – not even a Professor has a two decade obligation to a PhD student – I was much grateful that Sasan Gooran accepted to succeed. Sasan, always being very professional without compromising on a positive, friendly and trustworthy attitude, all contributing to a working atmosphere which I have always appreciated.

Pia Wågberg, then at SCA Research Sundsvall, for advising me to contact the Swedish Forest Research Institute (STFI, now The Rise Institutes/Innventia) when I was in the search for a Master Thesis project. Pia has always been positive and open, including when she later had moved to Innventia and we very solution-oriented settled a patent agreement between gonioLabs and Innventia. Petter Kolseth, for recruiting me as an industrial PhD student (1996) to STFI. Petter was an active sounding board, somewhat inclined for the information theoretic influences, that were soon abolished... but, interestingly, two decades later (2017) these influences were again reactivated. My industrial supervisor Per-Åke (“PÅJ”) Johansson, who introduced me to “the world of paper gloss” and pioneering application oriented image analysis work and not the least his friendliness. Marija Hedberg (succeeding Petter as the group manager) for always being professional, supportive and such a skillful manager. Sven Ängskog for his friendly and welcoming attitude, being a more established and experience PhD student, when we shared office room during my stumbling steps forming my PhD project. Siv Lindberg as a perception psychologist adding new important aspects and dimensions of human perception based evaluation.

In 2003 I was recruited by John Kettle, SCA Graphic Research, as an industrial PhD student to continue from Licentiate degree to a full PhD. Applied signal and image processing projects in Sweden as well as Austria – much rewarding.

Bo (Bosse) Andreasson – thanks for all the long discussions on research management – motivating.

Sven Forsberg an inspiration with his mix of being well vetted in research and with a strong interest in entrepreneurship. Another attribute is what I as laymen would describe Sven as a wine connoisseur. More importantly however, he organizes the most appreciated collegiate wine tastings (read: wine drinking get-togethers).

The design and construction of the measurement rig was most professionally influenced by Jarmo Tulonen and Krister Alvfors. Their deep knowledge in mechanooptics and contribution to the result are most appreciated and further described in Subsection 9.9.1.

In 2007 I ended my employment at SCA, starting a sole company (gonioLabs AB). In year 2008 Krister Källström, KAMI Research Foundation, for both the financial support during this year and Krister's strong engagement also in my efforts commercializing the research findings.

One aspect of being an industrial PhD student is the inherent conflict of stressing *applied* or *research* in applied research. In times of an economic pressure, as in the line of business of paper making during this period, the conflict is emphasized and a surprise to few. High ambitions may then be controversial but the history in this context tells us that the results of alternatives are generally either soon forgotten or costly experiences. I would like to thank all the deep, honest and insightful discussions on this subject with a majority of names on these two pages for educating me so much. Yours at times controversial high ambition inspired me. Thanks.

Stefan Gustafson for the very many hours spent on refining the language and pedagogics of **Paper IV** and **Paper V**.

This thesis has been proofread by Sasan Gooran, Daniel Nyström and Bo Andreasson; your help has significantly improved the thesis – thank you for all the efforts and comments.

My special thanks go to my family for always being supportive and even provided a most extended lodging. Last, but by far the most important person in my life: my loving fiancée, Ann, for putting up with me and for being my best friend.

Chamonix, August 2018
Mikael Lindstrand

Original work included in the thesis

- Paper I** Instrumental Gloss Characterization - In the Light of Visual Evaluation: A Review M. Lindstrand, *J. Imaging. Sci. Techn.*, **49**(1), 61-70 (2005).
- Paper II** An Angularly and Spatially Resolved Reflectometer for a Perceptually Adequate Characterization of Gloss M. Lindstrand, *J. Imaging. Sci. Techn.*, **49**(1), 71-84 (2005).
- Paper III** An Interactive Gloss Visualization Environment - For Measured or Simulated Surface Data M. Lindstrand, *J. Imaging. Sci. Techn.*, **47**(4), 346-356 (2003).
- Paper IV** Sensor Interpixel Correlation Analysis and Reduction: a Review M. Lindstrand, *J. Imaging Sci. Techn.* **63**(1) (to be published in 2019).
- Paper V** Sensor Interpixel Correlation Analysis and Reduction for Color Filter Array High Dynamic Range Image Reconstruction M. Lindstrand, submitted to *Color Res. Appl.*, (2018).
- Paper VI** Spatially and Angularly Resolved High Dynamic Range Reflectance Measurements for Forensic Document Inspection M. Lindstrand, *Optical Document Security - The Conference on Optical Security and Counterfeit Deterrence*, San Francisco, CA, January 23-25 2008: Reconnaissance International, (2008).
- Paper VII** Forensic DOVID reader, bridging 1st, 2nd and 3rd line inspection M. Lindstrand, In *Optical Document Security - The Conference on Optical Security and Counterfeit Deterrence*, San Francisco, CA, January 20-22 2010: Reconnaissance International, (2010).
- Paper VIII** Information Capacity Revisited - Reflections on Print Quality M. Lindstrand, and B. Kruse, In J. A. Bristow (Ed.), *Advances in Printing Science and Technology*, Munich, Germany, September 5-8 1999 (Vol. 26, pp. 175-184): Pira International, Leatherhead, UK, (2000).

Related work, not included in the thesis

- Work i** Instrumental Characterization of Security Holograms M. Lindstrand, In I. M. Lancaster (Ed.), *Holo-Pack•Holo-Print*, Toronto, Canada, November 18-20 2008: Reconnaissance International, (2008).
- Work ii** A Novel Security Hologram General Purpose Optical Scanner M. Lindstrand, *Euro-Atlantic Stakeholders Conference*, Stockholm, Sweden, October 1-2 2009: Swedish Civil Contingencies Agency, (2009).
- Work iii** Gloss: measurement, characterization and visualization - in the light of visual evaluation M. Lindstrand, Licentiate Thesis, Thesis No. 975, LiU-TEK-LIC-2002:48, Linköping University, (2002).
<http://citeseerx.ist.psu.edu/viewdoc/download?doi=10.1.1.105.5287&rep=rep1&type=pdf>.

- Work iv** Determination of gloss quality P.-Å. Johansson, and M. Lindstrand, *US6147750 (2000)*. (Patent family, also SE)
- Work v** Method of modeling and interactively visualizing the appearance of a surface M. Lindstrand, *SE524059 (2003)*.
- Work vi** Method of and Apparatus for Obtaining High Dynamic Range Spectrally, Spatially and Angularly Resolved Radiation Data M. Lindstrand, *US2011102784 (2011)*. (Patent family, also AU, CA, CN, HK, IN and SE)
- Work vii** Towards a technology-neutral standard - Novel DOVID reader paves the way to DOVID standard M. Lindstrand, *Keesing Journal of Documents & Identity (27)*, 21-25 (2008).
- Work viii** A conceptual approach to describe gloss variation in printing paper M. Lindstrand, Master Thesis, LiTH-ISY-EX-1624, Linköping University, (1996).
- Work ix** Goniolabs' Novel DOVID Reader R. L. van Renesse, *Holography News*, **22**(4), 4-5 (2008).

CONTENTS

Abstract	v
Populärvetenskaplig sammanfattning	vii
Acknowledgment	ix
Original work included in the thesis	xi
Part I Background	
1 INTRODUCTION	3
2 THESIS OPTIONAL PRELIMINARIES	7
2.1 The Licentiate thesis heritage	7
2.2 Inspection of documents — a general communication system	8
2.3 Communication protocol for optical document security management	9
3 VISUAL INSPECTION OF DOCUMENTS	11
3.1 Inspection of graphic paper gloss	12
3.2 Inspection of OVDs	13
4 DOCUMENTS — OPTICAL PROPERTIES, MEASUREMENT AND CHARACTERIZATION CHALLENGES	15
4.1 Properties and challenges of graphic paper gloss	15
4.2 Properties and challenges of OVDs	17
5 MEASUREMENT OF OPTICAL PROPERTIES OF DOCUMENTS	19
5.1 Measurement of graphic paper gloss	20
5.2 Measurement of OVDs	21
6 CHARACTERIZATION OF OPTICAL PROPERTIES OF DOCUMENTS	23

6.1	General purpose Cartesian metric information representations	24
6.1.1	Reflectance Volume	24
6.1.2	Reflectance Vector Map	24
6.2	Task-specific performance index, figure of merit and illustrations	24
7	VISUALIZATION OF DOCUMENTS	27
7.1	Non-interactive visualization	27
7.2	Interactive visualization	31
8	APPLICATIONS FOR OPTICAL DOCUMENT SECURITY	35
8.1	Three inspection classes	36
8.2	Factors of successful inspection	36
8.2.1	Frequency and ratio of inspection	37
8.2.2	Informing and training of inspectors	37
8.2.3	Feature conspicuousness	38
8.2.4	Falsifiers and verifiers features	38
8.2.5	Feature endurance – deterioration due to circulation	39
8.2.6	Technology advantage endurance – deterioration due to simulation advancements	39
8.3	Aspects of supplementary inspections for risk minimization	40
8.3.1	Supplementary inspection pitfalls	41
8.3.2	Supplementary inspection guidelines	41
8.3.3	Multi-modal supplementary inspection	41
8.4	Physically unclonable functions	42
8.4.1	OVDs of PUF potentiality	43
8.5	Principally new applications for OVD in security documents	44
8.5.1	Standardization of security feature specifications	44
8.5.2	Structural design and verification process to ascertain the conspicuousness of novel security features	45
8.5.3	Communication protocol for optical document security management	45
8.5.4	Monitoring security feature degradation due to circulation	46
8.5.5	Monitoring fraudulent attempts and inspection maintenance needs based on multi-class supplementary inspections	46
8.5.6	Structured documents revocation process	47
8.5.7	Physically unclonable function	48
8.5.8	Facilitating jurisdictional communication	48
8.5.9	Tamper resilient communication infrastructure	49

8.5.10	Improved tamper resilience based on mutually dependent multi-modal technology verification	50
9	SUMMARY OF ORIGINAL WORK	51
9.1	Instrumental Gloss Characterization - In the Light of Visual Evaluation: A Review (Paper I)	51
9.1.1	Contribution	52
9.2	An Angularly and Spatially Resolved Reflectometer for a Perceptually Adequate Characterization of Gloss (Paper II)	53
9.2.1	Contribution	54
9.3	An Interactive Gloss Visualization Environment - For Measured or Simulated Surface Data (Paper III)	55
9.3.1	Contribution	55
9.4	Sensor Interpixel Correlation Analysis and Reduction: a Review (Paper IV)	56
9.4.1	Contribution	57
9.5	Sensor Interpixel Correlation Analysis and Reduction for Color Filter Array High Dynamic Range Image Reconstruction (Paper V)	60
9.5.1	Contribution	60
9.6	Spatially and Angularly Resolved High Dynamic Range Reflectance Measurements for Forensic Document Inspection (Paper VI)	62
9.6.1	Contribution	62
9.7	Forensic DOVID reader, bridging 1st, 2nd and 3rd line inspection (Paper VII)	64
9.7.1	Contribution	64
9.8	Information Capacity Revisited - Reflections on Print Quality (Paper VIII)	65
9.8.1	Contribution	66
9.8.2	Thesis author's contribution	66
9.9	System integration — intersectional challenges and achievements	66
9.9.1	Thesis author's contribution	68
10	COMPARISON OF THE INTRODUCED SYSTEM AND UNIVERSAL HOLOGRAM SCANNER	69
11	SUGGESTED FUTURE WORK	71
11.1	Generalization of one-plane of inclination	72
11.1.1	Generalizing the measurement	72
11.1.2	Generalizing the characterization	73
11.1.3	Generalizing the visualization	74

11.2 Generalizing to photoluminescence materials	76
Bibliography	77
Part II Publications	

Part I

BACKGROUND

1

INTRODUCTION

This thesis is about instrument-based measurement, characterization and visualization of optical properties significant for a human vision-based inspection, of security documents. The concept of information security is often described as residing on the triad of confidentiality, integrity and availability (CIA), and the extensively used concept “optical document security” (ODS) [1], may be understood as documents representing a significant value, hence challenged by counterfeiting and forgery, which in turn are mitigated with optical based security features. The applications presented in this thesis were originally developed for two distinct fields of operation: graphic paper gloss (**Paper I – Paper III**), and optical properties of the so-called optical variable devices (OVDs) of optical document security (**Paper VI and Paper VII**). The other papers included in this thesis are described below. Although both gloss and OVDs are demanding multidimensional features to measure, characterize and visualize, applications of OVDs are the more challenging of these and require more general capabilities.

The included papers and manuscript are grouped into four themes: **Paper I - Paper III** focus on gloss variation, being an important print quality related topic for paper and board products of the graphics industry. **Paper I** [2] is a literature review on gloss. **Paper II** [3] presents measurements and characterizations in concert with results of human perception based evaluation to facilitate paper and board product development. The measurement, characterization and visualization are monochromatic (grayscale), spatially and angularly resolved. The optical model (the Reflection Vector Map, RVM) introduced characterizes and mediates gloss variation behavior of printed paper with high fidelity yet data compact. The introduced gloss variation characterization (the Gloss Angle Smoothness, GAS) acts in good agreement with results from experienced judges of perceptual evaluation for series of printed paper. This included also challenging series of minimal inter-sample differences resulting in high inter-judge differences from less experienced judges albeit the experienced judges essentially remain in agreement. In **Paper III** [4], the interactive visualization environment developed uses the RVM and is capable to mediate the optical behavior and give results of a perceptual evaluation of gloss variation in good agreement with a similar evaluation physical printed samples; again, for also challenging series of only minimal inter-sample differences;

Paper IV [5] and **Paper V** [6] (submitted manuscript) focused on image sensor imperfections of interpixel correlation (IC), i.e. increasing the intensity in one pixel

1• Introduction

only, will influence also other pixels. Presented are a literature review (**Paper IV**) and a novel approach to use the native color filter of the sensor as a “matched filter” to characterize and minimize the IC in a color image sensor camera (**Paper V**);

Paper VI [7] and **Paper VII** [8] focus on optically variable devices (OVD), which is an influential product-family in the security document industry. Although the measurement, characterization and visualization methods are as well tri-chromatic (RGB), as spatially and angularly resolved, hence six dimensional, we refer to the methods as 3D only implicitly referring the reflectance tri-chromaticity or ideally spectrally resolved and calibrated radiance. The optical model and the 3D RGB reflectance volume introduced characterize and mediate perceptually important characteristics of the optical features of OVDs (**Paper VI**). Further applications are demonstrated including visualization and instrument-based higher-order statistical characterizations related to visual inspection of OVDs (**Paper VII**);

Paper VIII [9] is the first published conference proceeding of the doctoral project; a forward-looking work of only minute scientific relevance judged on its own merits. However, put into the context of the chronologically later work (**Paper IV - Paper VII**) and with trivial generalizations, reforms to be of high relevance, opening for applications like standardizations and tamper resilient communication, potentially of high relevance for the security document industry.

The thesis remaining chapters 2 to 11 cover: Chapter 2 describes the relation to the prequel Licentiate thesis (**Work iii**) [10] and a complementary formulation of the problems addressed, here based on information theory. Chapters 3-5 all have sections differentiating the context either to graphic paper gloss or OVDs, Chapter 3 addressing visual inspection of documents, Chapter 4 describes general challenges of document optical properties, measurement and characterization, and Chapter 5 on measurement of optical properties as implemented in this thesis. Chapter 6 describes the implemented characterizations of optical properties of document, first a Cartesian metric and second task-specific characterizations. Chapter 7 describes the implemented visualizations with sections for non-interactive and interactive visualizations. Chapter 8, “Applications for Optical Document Security” may in a strict sense be included in Chapter 11, “Suggested Future Work” as the content is generally not covered in the included papers. However, contrary to the applications of Chapter 11, none of the applications described in Chapter 8 need any further development of the measurement, visualization or characterization methods described in the thesis. Also, as the content is generally not covered in the included papers is the motivation for the introductory Sections 8.1-8.4, as primers for the main message of the chapter, i.e. Section 8.5 “Principally new applications for OVD in security documents”. Chapter 9 summarizes the original work for the included papers, and for the measurement, characterization and visualization system integration, including the author’s contribution. In Chapter 10, the capabilities and relative strengths of the introduced system and the Universal Hologram Scanner are outlined as described by the late optical document security industry research authority Ruud van Renesse. The Part I Background is concluded with Chapter 11 “Suggested Future Work”. In Part II, i.e. Publications, the original papers are included.

Although the objective of the thesis is to develop and achieve the most capable and relevant measurement, characterization and visualization system in the context of human based (“first line”) inspection, one subject not directly related to first line inspection will be treated: so-called physically unclonable functions, PUFs. The subject will be treated in Section 8.4 and revisited in Subsection 8.5.7 indicating a principally new PUF application. The capabilities of the methods introduced in this thesis opens for these principally new applications of OVDs that are primarily used for first line inspection, which is the motivation for covering also the subject of PUFs in the thesis. These two OVD capabilities may also prove especially valuable when utilized in combination.

This Doctoral thesis is a continuation of preceding Licentiate thesis (**Work iii**) [10] and Master thesis (**Work viii**) [11] by the same author; the Licentiate thesis included the then unpublished manuscripts (**Paper I - Paper III**). The inter-relation between the Doctoral thesis and the Licentiate thesis is further described in Section 2.1.

2

THESIS OPTIONAL PRELIMINARIES

This chapter covers disparate subjects that are relevant for the PhD project but are not necessary prerequisites for the understanding of the remaining thesis. Therefore Chapter 2 may be skipped for a brief reading.

Subjects treated in the following Sections are: in 2.1, the continuation from the licentiate project (**Work iii**) [10] to the PhD project is described based on what was, in the year 2002, seen as promising future work; in 2.2 an alternative abstract description of the document inspection process viewed as a general communication system, that may facilitate the general understanding of the project deliverables; in 2.3 generalizing this description to cover also the remaining project deliverables.

2.1 The Licentiate thesis heritage

As the Licentiate thesis **Work iii** [10] studied graphic paper gloss only, where the more demanding applications of OVDs was introduced in the PhD continuation, it may be interesting to briefly reflect on the section “Suggestions for future work” (FW) in the Licentiate thesis and more specifically the suggestion implemented, with post-implementation experienced learned (EL):

- FW: Storing the whole scanned 3D information volume of reflectance data, to facilitate an enhanced differentiation capability of e.g. “silk” and “glossy” type surfaces. EL (**Paper VI**): The indicated potential explanatory benefit was confirmed. However, the application was now OVDs, as graphic paper was no longer in the scientific focus of the work.
- FW: Changing the monochrome to a color camera the range of application is extended, including characterization of both gloss and ink distribution jointly over a given sample area opening new research areas, e.g. the ability to study motif-induced gloss quality problems. EL (**Paper VI**): Again, although applied to OVDs, not graphic paper, the indicated instrument potential was confirmed.
- FW: A generalization of the algorithm to include the spatial Modulation Transfer Function (MTF) of the human visual system would improve the results of instrument based estimates of perception based evaluation. EL (**Paper VI**): Although applied to OVDs, the indicated potential explanatory

2 • Thesis Optional Preliminaries

benefit was strengthened however not confirmed by perceptual based evaluations.

- FW: The characterization of OVDs is within the capabilities of a measurement system modified according to the suggestions above. EL (**Paper VI**): The indicated characterization potential was confirmed.

2.2 Inspection of documents — a general communication system

This section is introduced to give an alternative view and description, that appeared only late in the PhD project. The ideas are therefore not supported by the published papers and manuscript. Another purpose of this section is to give a complementary abstract description of the project outcome, avoiding details that may obscure the main message. The suppressing of details may hopefully thus facilitate the understanding of the overall PhD project but also the understanding, contexts and purposes of the generalizations presented in future work.

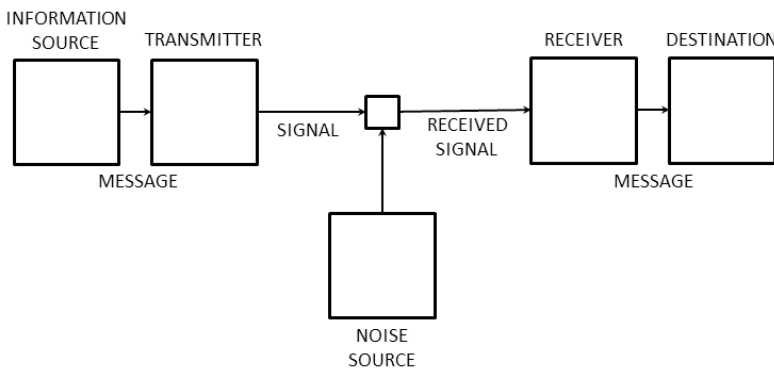

Figure 1 Schematic diagram of a general communication system, from the legendary work of Shannon [12, 13].

In Figure 1 a general communication system is described that is in the cited work [12, 13] accompanied with mathematical formulae. The capability and generality of this deceptively simple model can hardly be overrated and has formed the basis for modern information theory. The referred work defines a (the) measurement of information content, *entropy*, based on probability, a measurement of the transmitter capability, *channel capacity* that together forms the basis for the general theory relating the measurement, characterization and analysis of a general communication system.

In this work the **INFORMATION SOURCE** may represent a printing press, or an optically variable device (OVD) embossing machine; the **MESSAGE** may represent the content of this page in the printed version of this thesis, or the iridescent information volume of reflectance data of the OVD; the **TRANSMITTER** may represent the paper sheet, or the OVD; the **SIGNAL** may represent a half-toned (“raster”) image content, or the micro-structure surface (causing the iridescence) image; the **NOISE**

2.2 • *Inspection of documents – a general communication system*

SOURCE may represent a diversity of unwanted press/paper-related defects, or imperfections in the OVD embossing/substrate; the RECEIVED SIGNAL may represent the aggregate of intended print and defects (to be detected), or the aggregate of intended OVD and imperfections (to be detected); the RECEIVER may represent either a) a human reader (of e.g. this thesis), or an conventional flat-bed scanner, or b) a human inspector (of the OVD), or a multidimensional scanner; the MESSAGE may represent the detected page content (that may or may not resemble the intended printed content), or the detected iridescent information volume; the DESTINATION may represent either a) the vision/language/cognition centers in the brain of the human reader with the thesis message in the form of an appropriate cognitive representation, or a scanner RGB image representation, or b) the vision/language/cognition centers in the brain of the human reader with the OVD iridescent information volume message in the form of an appropriate cognitive representation, or a multidimensional scanner iridescent information volume representation.

In fact, this is not the first occasion describing optical document security as a communication process [1] but relating to also more fundamental information theory concepts, see e.g. the reference works [12, 13] of information theory, is new.

In the following, until Subsection 8.5.9, Figure 1 aims only as a complementary description of the project deliverables that may facilitate the overall understanding. In Subsection 8.5.9 and Section 9.8, this model adds to the motivation for the described further utilization of the presented measurement, characterization and visualization methods.

2.3 **Communication protocol for optical document security management**

The abilities to measure and characterize OVDs are necessary but not sufficient for both effective and efficient general optical document security management. An architectural approach to OVD product development is facilitated also by tools for feature analysis, simulation and visualization. Therefore, these capability sub-processes are also introduced in this thesis. The process in Figure 1 therefore now cover: OVD information design (message formation) – OVD interaction (transmitter) – noise – OVD scanner (receiver) – OVD software based analysis (message destination) – OVD software based characterization (message formation) – OVD visualization interface (transmitter) – noise – human inspector based detection (receiver) – human based interpretation and analysis (message destination). Note here that the entire sequence including the instrument-based measurement, characterization and visualization, and the human-based inspection of the virtual OVD is still described by the unmodified Figure 1, by using a recursive call.

In these abstract terms, the instrument-based methods may appear trivial and resemble a straightforward record-and-replay process. The challenges are however both profound and disparate in nature. As the dimensionality (degrees of freedom) of the influential appearance features is large for OVDs, i.e. having multiple principally different influential characteristics, a simple play-back function will not suffice as a capable and general tool for analysis and simulation. Instead abilities to sense and

2 • Thesis Optional Preliminaries

capture multidimensional signals, data reduction to characterizing features of high explanatory capability, appropriate protocols and visualization interfaces that mediate the optical behavior, all considering the perceptually significant aspects, are necessary for such a tool. Indeed far more intricate than a trivial record-and-replay process would be able to handle.

These desired but demanding instrument-based abilities are topics covered in the thesis.

3

VISUAL INSPECTION OF DOCUMENTS

The appearance of an object is a visual sensation caused by the light, or more formally the electromagnetic radiation (radiant power) within the wavelengths detectable by the human visual system (HVS), reflected from the object under study. The reflected light is a consequence of radiation that has interacted with the object. The object incident radiation may be characterized as an energy distribution as a function of wavelengths, and this energy is altered (normally attenuated) in its interaction with the material.

The light is in the HVS detected by the tri-chromatic (short, medium and long wavelength spectra) receptors, in the case of well-lit “day-light” photopic vision (opposed to dim-light scotopic vision). The HVS signal processing is, even if restricted to color perception only, hugely intricate and engaging, covering e.g. opposite-color representation, extensive data compression within the visual nerve track and temporal and spatial context based visual processing. Being influential characteristics of the HVS they also have influence on this work but are nevertheless left outside the scope of this thesis. The HVS is with few exceptions in this thesis instead treated as a black-box system, using a phenomenological description approach.

When performing a human visual perception based inspection, it is essential that the judgement is influenced by all the relevant aspects of the optical behavior related to the task (**Paper I**) [2]. This apparent obvious statement is however only possible if the inspection task is understood and performed such that all aspects are indeed observed and perceived. This is often challenged by e.g.: assumed understanding of concepts, lack of or otherwise inappropriate communication of the inspection task or inappropriate evaluation environment such as illumination not suited for the inspection task. Each of these challenges may invalidate the result of an evaluation in its entirety.

Further, the judgement should not be influenced by other aspects than the relevant. The most challenging disturbing factors are task-specific, too specific and concrete suggestion may be counter-acting, but a reflected awareness of potential sources of disturbances is a necessary prerequisite when mitigating this problem. However, one disturbing factor that often challenges the result is personal preferences having a stronger influence on the results than the task at hand motivates. A crisp clear question for the judges and well introduced related concepts, possibly also collated in the judges own words, may limit the risk of an overly strong personal preference influence.

3 • Visual Inspection of Documents

The difference in judge's responses should be due to the evaluation of the task, not due to the deciphering and interpretation of the question.

This thesis has not penetrated the abundance of research in the field of visual perception based evaluation of documents. In fact, this subject is only touched in the gloss review paper (**Paper I**) [2] and in the papers performing panelist visual inspection of gloss in graphic paper (**Paper II**) [3] and (**Paper III**) [4]. However the challenges experienced, as also indicated above, motivate significant efforts put in the design, implementation and verification of already the perceptual evaluation protocol. Even with the best efforts, results may not meet the desired explanatory power. A high inter-panel variation may indicate that the difficulty of the task was beyond the capacity of the panel of judges. Such challenges can be reduced, albeit not eliminated, by know-how in statistics, and effort by increasing the number of panelists.

The above are important notes on the general framework of visual inspection. The following will describe also some specific aspects or aspects of especial importance, for the two distinct fields of operation: graphic paper gloss and OVDs.

3.1 Inspection of graphic paper gloss

To efficiently access and observe aspects of the multidimensional optical behavior of gloss variation in graphic paper [14, 15] one approach, adopted by many experienced judges, is to bring the document into a convex shape (**Paper I**) [2], see Figure 2. The judge thereby accesses a range of different inclinations revealing many of the perceptually significant gloss variation aspects, at one same observation. This approach therefore facilitates the inspection.



Figure 2 Illustration of bringing a surface into a convex shape to facilitate inspection of angle-dependent appearance, such as gloss characteristics.

The inherent multidimensional characteristics of gloss described motivates why perception based evaluation of gloss and gloss variation may be difficult, especially if the judge is not trained or the observation conditions are not well suited for the task.

As human visual perception based evaluation of gloss sometimes tend to be overly influenced by the preferences of a panel of judges the importance of evaluation protocol, as motivated above, must be emphasized.

3.2 Inspection of OVDs

The just described benefit of bringing the document into a convex shape, see Figure 2, is equally applicable for the angle dependent optical behavior of optically variable devices (OVDs). The judge thereby accesses a range of different inclinations revealing a range of inspection significant aspects.

To detail this further, OVDs are substrates that significantly change in appearance as a function of inclination, relative to the illumination and observer [1]. The unprecise term “significantly” causes the concept to be more a relative description of substrate characteristics rather than an absolute description or a definition with crisp criteria. A glossy graphic paper does, as mentioned, indeed change in appearance as a function of inclination, possibly from observing high contrast intensely chromatic bulk reflections to specular all “flat out” (saturated or blinded due to too high intensity) low contrast and low chromatic reflections. This behavior is nevertheless, in this context not considered to show a *significant* change of appearance as a function of inclination. Graphic paper is hence not categorized an OVD. This vagueness may motivate a revision of the OVD definition to include also concepts like “non-conventional”, “unexpected” or conspicuous, i.e. perceptually striking or “eye-catching”. But the nomenclature is established and therefore adopted in this thesis.

Generally, designing inspection tasks, vague questions should be avoided as the results become difficult to evaluate and interpret. However, the task may for specifically well-motivated investigations be to capture non-crisp phenomena. The scrutinizing evaluation of an OVD being genuine may be guided by questions either of the type: “To what degree does the optical behavior of the OVD meet your expectation, based on previous evaluations of genuine banknotes of the same denomination?”, or “To what degree does the optical behavior of the left evaluated OVD resemble the optical behavior of the of the right genuine OVD?”. The second type is more well-defined, and hence requires less experienced judges to achieve a desirable small inter-judge variance. Nevertheless, the first type may be well motivated if the aim is to capture the ability of a judge to evaluate a sample relative to experiences and recollections of a genuine OVD. This, in contrast of evaluating a sample based on a pair-wise comparison relative to a genuine OVD.

The bottom line is however that the evaluation protocol, including the exact phrasing of the questions to the inspectors, should be as well-define and as specific as motivated by the task. Too open and vaguely formulated questions cause the interpretation of the results a daunting task by itself, and may well invalidate any meaningful conclusion.

4

DOCUMENTS — OPTICAL PROPERTIES, MEASUREMENT AND CHARACTERIZATION CHALLENGES

As described, this work has been applied to two different fields of operation: graphic paper gloss, and optical document security (ODS). Although the product characteristics differ in terms of the relative importance of e.g. topography, color etc. they share significant aspects which influence the measurement, characterization and visualization methods.

The potential wide dynamic range of reflection from (high contrast of) paper gloss as well as OVDs cause also less sensitive regions of the HVS contrast sensitivity function [16, 17] to be detectable by a human. In other words, for such wide dynamic range signal the range of spatial wavelengths detectable by a human is larger than for a signal of moderate dynamic range and may influence a perceptual evaluation (**Paper I**) [2] (**Paper VI**) [7]. This adds to the measurement performance requirements regarding e.g. the point spread function.

The following two sections will detail the differentiating characteristics of the distinct fields of operation: graphic paper gloss and OVDs.

4.1 Properties and challenges of graphic paper gloss

A perfect diffusor (a Lambertian surface) reflects light equally in all directions¹ and hence shows an angular independent appearance. A perfect diffusor is however a theoretical concept with only approximate realizations. Matt uncoated and unprinted paper (such as plain “office paper”) may be considered an approximate perfect diffusor (sic!). This means that the incident light is reflected diffusely and approximately equal in all directions almost irrespective of incident light beam type and direction. Glossy papers, in contrast, have a pronounced angular dependent appearance. The inclination

¹ In a physical sense this is not correct, as the projected surface reduces with gracing angle of appearance; the human visual system do however implicitly compensate for this effect causing a perfect diffusor *appears* to reflect light equally in all directions.

4 • Documents — Optical Properties, Measurement and Characterization Challenges

of the product relative to the illumination and observer hence has a distinct influence on the appearance of the product. Somewhat simplified, the reflected light can be described as the intermixture of the light originating from bulk scattering and the light from specular reflection (gloss). The bulk scattering is an interaction within the material which leads to light reflected in a large solid angle² from the surface. The specular reflection is a surface interaction, reflecting light in a locally narrow solid angle at an angle approximately equal but opposite to the angle of incidence. For paper substrates, being non-conducting, the bulk scattering has in general a significant influence on the appearance and is responsible for the color appearance, if present, while the specular reflection in general preserves the color of the incident light. For white light illumination, this means that the specular reflection is also white. Color measuring geometry may be e.g. $45^\circ/0^\circ$ (angle defined as the bisector of the optical axis relative to the surface normal for incident irradiance and detector, respectively). The color measurement geometries are designed to be dominated by and receive a proportionally large amount of (bulk) scattering and ideally avoid or at least have only a small proportion of white (specular) light reflection. The gloss measuring geometries, of e.g. $45^\circ/45^\circ$, receive the reflection in a specified narrow solid angle at and close to the specular angle.

As the specular reflection from a non-conducting surface does not carry chromatic information about a print and the print being the information conveyor, the specular reflection may be seen as a distortion, which hides the information intended by the print [18]. There are two principally different approaches of reducing the information loss caused by the specular reflection. One is by causing the specular reflection to be less intense, e.g. by anti-reflex coating (i.e. a graceful gradation of refractive index thereby reducing the reflections) of the surface. Another approach is to concentrate the specular reflections into a limited solid angle only, e.g. by making the surface macroscopically smooth, and hence making the specular reflection easy to avoid by the observer. The first approach is used e.g. in high quality silky art-paper which has a matt surface with a low degree of specular reflection almost independent of the viewing condition. The second approach is evident in high-gloss magazines, having highly glossy surfaces where the gloss is concentrated into the global specular direction only and hence easily avoidable.

Avoiding the specular reflection is, as said, necessary in order to achieve saturated and vivid colors. For surface having a pronounced small-scale topography, i.e. not being macroscopically flat, local specular reflections may deviate significantly from the angle of global specular reflection. Hence the gloss and especially local gloss variation in angles/directions other than the global specular direction influence the color as perceived by a human observer. For such material a characterization method claimed to be relevant in also the contexts of print quality, perceptual evaluation and inspection by humans, need to be angle resolved.

² The two-dimensional angle in three-dimensional space that an object subtends at a point.

4.2 Properties and challenges of OVDs

Optically variable devices (OVDs) may be categorized into iridescent and non-iridescent, i.e. essentially color variable and color constant, respectively. A number of principally different physical principles may be involved in the OVD behavior, some are trivial to simulate and counterfeit, others are demanding to simulate and counterfeit. Those among the latter group that also have a conspicuous OVD behavior, thus are both counterfeit resilient and literally eye-catching are of especial interest as they facilitate first line inspection and authentication [1].

One example of such OVD based on (iridescence) diffraction, forms a large group of features: diffractive optically variable devices (DOVIDs) realized in banknote circulation for the first time in 1988, a Kinegram[®] originated by Landis & Gyr (subsequently renamed OVD Kinegram) and produced on foil by Kurz, appeared on the Austrian 500 schilling. Already in 2003 150 denominations from 78 issuing authorities used DOVID features [19] and the development of the technology and the adoption of DOVIDs in security documents continues.

Another example of such OVD based on (iridescence) interference stems from a more than 100 year old invention by Gabriel Lippman recording color photographs in monochromatic (black and white) photographic emulsions [1]. Although the resulting optical performance was good, the practical execution was very demanding that hampered the applicability. In 1999 Hans Bjelkhagen filed a patent [20] where much of these challenges were overcome by exchanging the photographic emulsion for a panchromatic holographic photopolymer film [21-23]. This revisited and refined Lippman photograph application has multiple desired characteristics: individualized information facilitated, cannot be copied by holographic techniques and in general mitigating forgery and counterfeiting. Note however, although the interference respond to a change in the inclination, e.g. moving away from a normal (at right angles) view causes color shifts towards shorter wavelengths, the optical behavior of this type of material is not characterized exhaustively by the measurement system described in this thesis. A modified system allowing a controlled variable wavelength of the irradiator, alternatively a controlled variable angle between illumination and receptor would facilitate more exhaustive characterization while maintaining a signal-to-noise ratio at the necessary high level as of the characterization system in this thesis. Nevertheless the system (as is) mimics a human based inspection, having a fixed angle between illumination and eyes while changing the relative attitude of the material under inspection, and therefore remains a highly motivated type of characterization.

A third such OVD significant for ODS applications are moiré magnification [1] causing a horizontal axis tilt a counterintuitive horizontal (non-iridescent) movement of the image and likewise for a vertical axis tilt. This feature Motion[®] is invented and developed by Nanoventions (USA), and realized by Crane Ltd. (USA) for the first time in year 2006 on the Swedish 1000 SEK banknote [24], later e.g. in the US \$100 issued 2013 [25] and many others.

OVDs may also be characterized as either a) individualized, where each individual instance of security document has an OVD with uniquely engineered characteristics, (often in Passports) or b) universal, where each individual instance within a group of

4 • Documents — Optical Properties, Measurement and Characterization Challenges

security documents has an OVD with ideally identical characteristics as the other instances within the same group (often in a banknote single denomination). The physical principals, production procedures and potential applications may differ, comparing these two types of OVDs. However, with respect to this thesis, the difference between a) and b) imply no principal challenge and the methods presented are well-suited to handle them both.

The counterfeit resilience of a given OVD realization is as described above conditioned in part on how difficult it is to simulate and mimic the OVD behavior. If the production of even a fair simulation of the genuine OVD is estimated a challenge beyond the capability of the vast majority of counterfeiters, the OVD meets one necessary criterion for an effective counterfeit counter-action. However, this estimation is not static but constantly challenged by motivated counterfeiters, their high efforts and improving capabilities (as the capabilities are assumed an accumulation process). Hence the key expression “reasonably demanding” resides in the case of the administration and management of security documents, on the continuous advancement of the technology and revisions of the OVD features to technically more demanding features. Such revisions are necessary to limit the risk that simulations show similarities with the genuine OVDs.

OVDs are generally said to be easily authenticated by human based visual inspection [1]. The statement relies on the assumption that the difference, as judged by a visual evaluation, between the genuine and the counterfeit products are large enough. Only if the visually judged difference is large enough is the visual inspection task easy and the verdict reliable. The ability to make detailed and objective estimations on the difference, as judged by a visual evaluation, is therefore of importance when valuing the level of security of candidate OVDs as an optical security feature.

The lack of established objective instrument-based characterization of the relevant features influencing inspections in general and especially first line inspection hampers the applicability of OVDs for significant actors within the business of optical document security. Examples of actors and issues of relevance in this context are:

1. Developers and suppliers: Providing measures and illustrations of improved optical feature, such as higher optical yield (higher quantum efficiency), improved angle definition (reduced angle cross-talk) and improved wear resistance. This facilitates a pedagogical communication during negotiating on document characteristics.
2. Issuers of security documents. A) Quality verification over time and delivered batches, of the relevant optical features. B) Benchmark of different potential suppliers.
3. Forensic professionals. Forensic work does not stop when a product is judged a counterfeit. On the contrary, evaluating the origination (pedigree analysis) of counterfeits is essential and challenging task e.g. for the clear presentation of facts in court.

These are a number of actors and use-cases within the business of OVD products for which relevant objective characterization would support the business process, fuel the product development processes and ultimately improve the OVDs as a security feature.

5

MEASUREMENT OF OPTICAL PROPERTIES OF DOCUMENTS

The measurement system was initially developed and implemented to measure perceptually relevant characteristics of graphic paper gloss [11]. This motivated an achromatic spatially and angularly resolved measurement system. Later the system was generalized to measure perceptually relevant characteristics of OVD, hence including also the ability of tri-chromatic (color) and high dynamic range measurements.

Established optical measurement equipment single-out well-defined and narrow aspects of the paper or OVD materials but nevertheless omits features of significant influence for a human based inspection. If the multidimensionality of the input is crucial for a proper perceptual evaluation, then a well-performing instrumental characterization system must also access multidimensional information [26]. The multidimensional optical behavior is only vaguely described by established measurements of e.g. mean-gloss values, reflectance or similar one-dimensional metrics. Instead, the complexities of the visual and more capable instrumental characterizations must match each other (**Paper I**) [2] (**Paper II**) [3]. This is the motivation for developing a more capable instrument.

Another aspect of the aim of the measurement system to capture the perceptually influential characteristics is the choice of the measurement system free variables. Besides the obvious image-related variables, the angle resolution was chosen to correspond to the change of inclination of the document (local) surface in relation to the fixed-angle illumination-camera configuration. The motivation being that when inspecting a document, it is common to change the inclination of the document in relation to fixed positions inspector and illuminator. Less common is e.g. to change the position of the inspector or the illuminator, where the other two (of document, illuminator and inspector) are fixed. The measurement configuration was chosen to best resemble a most common inspection environment set-up.

The characteristic features and challenges of these two instances, paper gloss and OVD, of the measurement system are further treated in the following.

5.1 Measurement of graphic paper gloss

Conventional, established and standardized measurements of graphic paper gloss considers only *how much* (or the ratio) of reflectance in a narrow specular direction, implicitly “the more the better”. By instead considering also perceptually negative aspects of gloss, as indicated in Chapter 4, it is possible to include perceptually significant aspects in the measurement that is ignored by conventional gloss measurements for the paper and board industry. Conventional measurement approaches may be especially unsuited for products having a high degree of visible structure, often related to heat-set web-offset printed Light Weight Coated (LWC) papers, where the heat, moist and encapsulated fibers may yield an unfavorable “cocktail”, causing visible fiber lifting. For such materials, the gloss as evaluated by a human judge effectively reveals the perceptually distinctive and often very disturbing surface structure. In contrast, a standardized gloss meter neglects this perceptually disturbing aspect. Only the indirect effect of an absence of reflectance in the desired direction is detected by such gloss meter. Standardized gloss meters therefore have low specificity and low explanatory power for perceptual gloss.

For such type of products, a lower degree of gloss may likely be perceptually favorable, as it would cause the unwanted surface topography to be less apparent. For graphic paper products, having a surface topography detectable for the unaided eye, the level of gloss has either an optimum or threshold level over which the topography only becomes increasingly annoying. The method introduced in this thesis facilitates the measurement and further analysis of such questions, where the established gloss measurement systems within the business of graphic paper do not.

Angle resolved measurements such as a Bidirectional Reflectance Distribution Function (BRDF), measures the fraction of the incident radiant power reflected in each outgoing direction. This is a capable type of laboratory instrument for detailed angle resolved measurement of the surface small area measured. However, most common types of BRDF measurement lack spatial resolution. But the spatial variation of gloss, *gloss variation*, is a significant component of the appearance of gloss. A spatially unresolved BRDF measurement is hence in general not a sufficient measurement for applications of gloss appearance. The need for more powerful reflectance measurement techniques has been addressed for a wide variety of applications [26, 27]. Dana et al. have published a database of images taken in different geometrical set-ups, a series of over 200 different combinations of viewing and source direction, for each of over 60 different real-world surfaces, and this has been suggested as a starting point for further developments of “Bidirectional Texture Functions” (BTF).

Another feature of the reflection from non-conducting surface is that the specular reflection polarizes the incident radiation, whereas the bulk scattering de-polarizes the incidence radiation. This is important information when determining the origin and causes of the light measured, e.g. when investigating the causes of an optical behavior of a material, to better understand and to gain knowledge of the physics involved, e.g. to be used in inventive product work to achieve novel optical behavior. The human visual system does not, however, have the ability to sense the state of polarization; the light is perceived the same irrespective of the state of polarization. Hence when ob-

jects are measured with the purpose to estimate or simulate the perception of the human visual system, the state of polarization should not influence the measurement. This apparent obvious statement may still be motivated as numerous attempts for improved gloss meters have indeed deliberately introduced filters to detect and let the result be influenced by the state of polarization in the detected radiation.

The gloss related studies in this thesis is not limited to paper. However, the often-visible topography of paper and the corresponding angle dependent gloss behavior causes paper to be technically demanding product segment, measuring the perception significant features.

5.2 Measurement of OVDs

The just described system was later generalized to a tri-chromatic measurement by exchanging of the monochromatic image sensor for a color filter array (CFA) Bayer mosaic red green blue (RGB) image sensor suited for color optically variable devices (OVDs). The metallic foil diffractive optically variable devices (DOVIDs) or OVD further have a potential of a high dynamic range of reflections and image contrast [1] e.g. in relation to paper and board products. High dynamic range (HDR) and high image contrast may cause the ever-present interpixel correlation (IC), *pixel-to-pixel crosstalk*, to become a significant problem (**Paper IV**) [5]. The CFA sensor further worsens the problem as IC result in color crosstalk that is, spill-over between distinctive measurement dimensions [28-30]. For this reason a new sensor-level IC limiting algorithm was developed and implemented that significantly reduces the IC, color crosstalk as well as increase the MTF and the signal-to-noise ratio (SNR). (**Paper IV**) [5] and (**Paper V**) [6] cover a literature review and details on the implemented algorithm respectively.

The OVD optical behavior is by definition highly angle-dependent. For most types of OVDs this angle-dependence is most profound when the OVD inclination is changed relative to fixed angle inspector-illuminator configuration. This behavior facilitates applications in human based inspection as the intuitive inspection procedure, as described in the introduction of this chapter 5, reveals the most profound angle-dependent behavior. However, for interference based OVDs (see Section 4.2) the angle-dependence is most profound when instead inspector-illuminator angle is changed or when changing the wavelength of a monochromatic illuminator. Still, also the interference based OVD do respond, albeit to a lesser degree, to a change in the OVD inclination relative to fixed-angle illuminator-camera configuration. If instead the inspector (camera) is e.g. moving away from a normal (at right angles) view, this causes color shifts towards shorter wavelengths. But this optical behavior is not characterized exhaustively by the measurement system described in this thesis. A modified system allowing a controlled variable wavelength of the irradiator, alternatively a controlled variable angle between illumination and receptor would facilitate more exhaustive characterization while maintaining a signal-to-noise ratio at the necessary high level as of the characterization system in this thesis. Nevertheless the system (as is) mimics, as described in the introduction of this Chapter 5, a human based inspection, having a fixed angle between illumination and eyes while changing the relative attitude of the

5 • Measurement of Optical Properties of Documents

material under inspection. Therefore this system remains a highly motivated type of characterization also for interference based OVDs.

Section 5.1 argued for not letting the state of polarization influence measurements in the context of graphic paper. This is in no conflict to the fact that polarizing material is frequently used in optical document security features, influencing the appearance, e.g. using a polarizing filter to facilitate the detection of the information by the human visual system is otherwise unable to perceive [1]. For such applications, a proper instrumental based measurement should likewise include the state of polarization, described further in Chapter 11.

6

CHARACTERIZATION OF OPTICAL PROPERTIES OF DOCUMENTS

Two principally different approaches have dominated the studying of reflection from materials: physical and geometrical optics. The physically based approach is more comprehensive and thus more general but the simpler mathematical form of the geometrical approach makes it more accessible. Geometrical optics is applicable in situations where the electromagnetic character of light can be ignored, and approximations such as *reflections* of light rays give a sufficiently accurate description. To understand diffraction and interference phenomena, it is however necessary to use physical optics. Commonly used models are the Beckmann-Spizzichino [31] (physical) and Torrance-Sparrow [32] (geometrical) models. A thorough comparison of these models has been conducted and a generalization into a unified framework based on both these approaches has been suggested [33]. These models and subsequent off-springs are the obvious candidates for modelling general problems of reflection from materials. Task-specific characteristics may however relax the need for general models and extensively comprehensive solutions, where instead simpler approaches may be more effective, achieving a sufficiently high fidelity at a reasonable effort and, in all, a best choice. As the characterization aims to resemble (aspects of) human visual perception based evaluation, causing the appearance of the object to be vital and the invisible effects to be irrelevant, or at least of secondary importance, certain characterization simplifications are appropriate which will be described in the following.

Assuming the measurement of the perceptually significant reflectance behavior described in Chapter 5, is perfect in its completeness the resulting data set may nevertheless be close to useless e.g. due to lack of accessibility. The data set may be overly redundant hence massively and unnecessary large and it may further lack an intuitive interpretation. Such data set will prohibit further processing, reasoning and insightful conclusions. Sensible consolidation (“data compression”) and rearrangement of the large *data* set into a compact, less redundant, *information* set may ideally approach non-redundant information set without losing relevant information, i.e. still being complete. Such *characterizing* information set promotes further processing, reasoning and insightful conclusions.

This chapter introduces two types of characterizations: in Section 6.1 a general purpose Cartesian metric (image based) representation for visualization or further processing is described and Section 6.2 describes a set of task-specific characterizations.

6.1 General purpose Cartesian metric information representations

Two general purpose Cartesian metric information representations are introduced. The first representation aim primarily for information completeness and the second aim primarily for information compactness. These two representations are described in the following two subsections.

6.1.1 Reflectance Volume

The introduced RGB Reflectance Volume (RV) is the information volume of reflectance data, i.e. the measurement full data having the full angle resolution but also the curved surface projection retransformed into Cartesian spatial metric information. The RV hence is 3D information resolved in (2D) image or spatial space, and (1D) angular space. Each volume element, or voxel (c.f. pixel), holds the RGB reflectance information for the spatially-angular-coordinate. As indicated already in Chapter 1, although this tri-chromatic (RGB), spatially and angularly resolved information set is literary six dimensional, we refer to it as 3D only implicitly referring the reflectance tri-chromaticity (or ideally spectrally resolved and calibrated radiance).

This spatially (34 μ m), angularly (0.13°) and dynamically (22bits in each RGB-channel) highly resolved and spatially and angularly calibrated low-noise information set, is accurate first line influential characteristics of OVDs.

6.1.2 Reflectance Vector Map

The introduced Reflectance Vector Map (RVM) is a local facet approximation representation [11] (**Paper II**) [3] and hence more compact information set than the full RV. The RVM which is derived from the RV holds spatially resolved apparent angle (direction of peak intensity) and relative reflectance information and aim to be an approximation of the characterizing optical behavior of the surface measured. The facet apparent angle includes the often-present micro-roughness caused off-specular peak-intensity angle estimation [15, 32, 34-39], which is desirable especially when relating measurements to human perceptual based inspection (**Paper II**) [3].

6.2 Task-specific performance index, figure of merit and illustrations

For graphic paper gloss applications, the introduced gloss homogeneity index called “Gloss Angle Smoothness” (GAS) operates a fuzzy rule set on the RVM local (facet) angle information. This part-result, a goodness measure (-1, +1), is multiplied with the local relative reflectance yielding a local result. The mean over all facets result the

6.2 • *Task-specific performance index, figure of merit and illustrations*

GAS as an estimation as the gloss homogeneity as evaluated by a group of experienced judges [11] (**Paper II**) [3].

For OVD applications, by using image processing it is possible to identify and masks out (select) target spatial regions of interest, e.g. the denomination “100” digits, see Figure 3 (although the theme of the figure is another), or other graphic details. Signal processing on this target region only, avoiding surrounding area distortion results in an enhanced sensitivity characterization and facilitate any further processing based on the inclination dependent RGB reflectance. Examples are studies of colorfulness (saturation), e.g. a) the influence of circulation (“wear”) on optical performance and b) reproducibility, i.e. characterization of the differences of two instances of un-circulated banknote OVDs, ideally of identical appearance (**Paper VI**) [7]. These are only two of an abundance of potential performance indices or figure of merits relevant as OVD performance evaluation. The described image and signal processing may be fully software-controlled and automated, based on once-defined criteria for identifying the target region.

The signal processing may consider also the modulation transfer function (MTF) of the human visual system [40], causing size of graphic details and viewing distance to influence the result, see Figure 3 (from (**Paper VI**) [7]).



Figure 3 Illustrations of spatial filtering according to the MTF of the HVS. The upper row corresponds to a new (not circulated) sample. The lower row corresponds to sample heavily circulated showing a pronounced degree of wear. The left column corresponds to the raw (not filtered) image. The middle column: filtering corresponding to a viewing distance of 50 mm. Right column: filtering, viewing distance 300 mm.

VISUALIZATION OF DOCUMENTS

By visualization of documents we here refer to virtualized appearance reproduction of measured and characterized physical original. In general, a visualization tool may be vital to study certain aspects of a problem and help revealing new aspects of the task – given that the visualization is reasonably well designed and trustworthy in the context of the task at hand. Visualization tools, when successful, give new and multiple aspects of problems, and thrive ideas that may facilitates the development of solutions. Similarly, performing a visualization tool-based visual evaluation, it is important that the judges may assess all the influencing dimensions for a perceptual evaluation. If the tool is unable to fulfill this, e.g., if the judge is not able to change the inclination of the sample appropriately, the directed reflectance information and hence the result of the visual evaluation will inevitably become stunted. This is reported in the literature [14, 15] for physical (non-virtualized) surfaces (**Paper I**) [2].

Two types of visualization tools were developed and implemented, a non-interactive and an interactive tool. A common goal for both tools is to reproduce and mediate the perceptually significant optical behavior of the physical original surface measured and characterized.

7.1 Non-interactive visualization

The non-interactive visualization tool developed and implemented operates on the RV representation, i.e. the full angle resolution. One sub-type, or instance, of this tool visualizes the characterized OVD at a fixed inclination, corresponding to a horizontal slice in the RV, with Cartesian metric (i.e. a conventional image representation). This facilitates e.g. detailed pair-wise comparisons of ideally identical but in reality at best similar samples, however still with a distinctly separable appearance. The reasons for the difference may be due e.g. to production inaccuracies or circulation, see Figure 3 up-left and down-left sub-figures. Another example of this tool instance is the detailed study of the iridescence behavior of an OVD in well-defined and possibly agreed upon angles of inclination, see Figure 4.

7 • Visualization of Documents

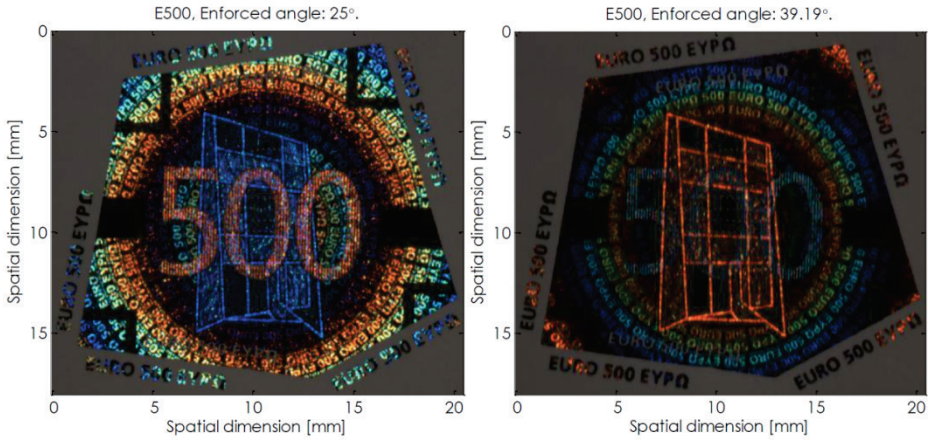

Figure 4 Spatial (image) representation samplings of the RV of the diffractive characteristics of one same €500 Alphagram[®], the left sampled at 25.00°, the right sampled at 39.19° out of the RV; comment: 0° correspond to specular reflection and the light source and detector is fixed at 45°.

A second instance of this visualization tool is based on the first instance but having also an orthogonal slice of the RV. The added slice corresponds to one sample coordinate row represented at all the measured and characterized sample inclinations, i.e. an extremely sparsely sampled version of the RV resulting a spatio-angular twin-slice representation, see Figure 5.

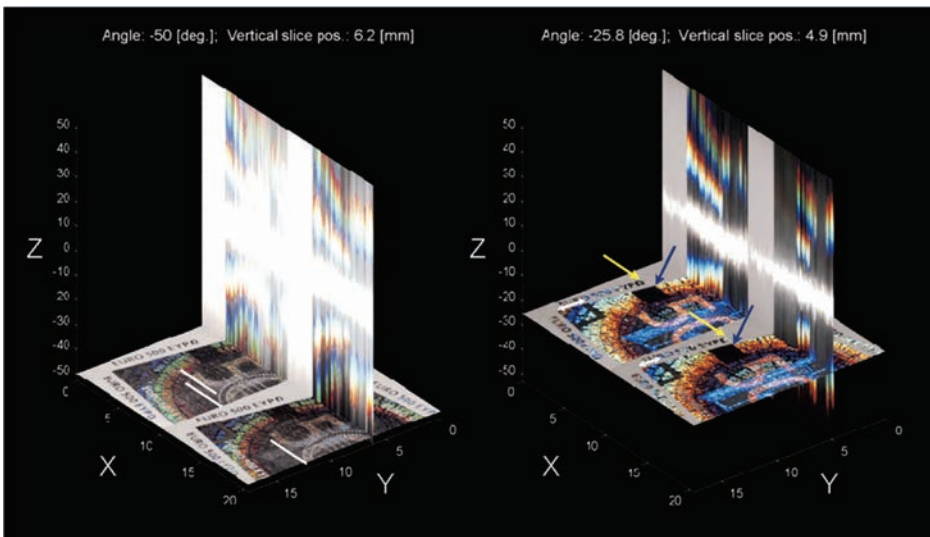

Figure 5 Spatial and angular representation of the diffractive characteristics of two genuine €500 Alphagram[®], assumed to ideally be identical but in reality are different, see body text for details.

For OVD applications, such twin-slice visual direct access to multi-dimensional high-resolution, high-fidelity, spatially and angularly well-controlled inspection or pair-wise comparison, are vital novel capabilities. These capabilities e.g. facilitate the scrutinizing study of critical OVD functionality, see Figure 5. The illustration shows two different spatial and two different angular slices in the RV representation, for a pair-wise comparison. Zero order specular reflection occurs at $Z = 0^\circ$.

The explanatory power of the visualization method may be indicated by noting inter-sample differences of already genuine OVD. The response of the two samples should ideally be identical but due to OVD production imperfections differences are apparent and may be characterized with the help of the presented system. In the left half-figure in Figure 5, the difference in relative positions of digits "50" and the de-metalized (perforated) "€'-fraction, see the guiding white lines added: two separate (left sample), two overlapping (right sample). This difference (separate vs. overlapping) in white line configuration points at the inter-sample difference in the relative position of the two graphical elements "50" and the "€'-fraction.

In the right half-figure in Figure 5, the difference in positions of de-metalized rectangle edges, white double arrows: longer (left sample), shorter (right sample); difference in relative positions between dark rectangle, blue arrows, and neighboring text, yellow arrows. Difference in angle response (i.e. vertical slice) are small but may be discerned as a relative difference in the color nuance of the digits "50", see left half-figure, less saturated colors (left sample), more saturated colors (right sample). These differences were only illustrating examples of a multitude of differences possible to be characterized, for the larger set of OVDs evaluated.

In a third instance image sequences (video) based on the described first and second instances, where either one slice or two slices traverses the RV, hence varying spatial and angular coordinates to effectively mediate the optical behavior in videos.

It should be noted that the illustrations in this thesis are of significantly lower resolution and dynamic range than mediated in the native computer applications, that utilize the characterized low-noise information, the spatial resolution ($34\mu\text{m}$), the angular resolution (0.13°) and the dynamic range of RGB (22 bits) much more effectively. To better mediate or at least indicate the illustration potential, Figure 6 zoom into each of these dimensions.

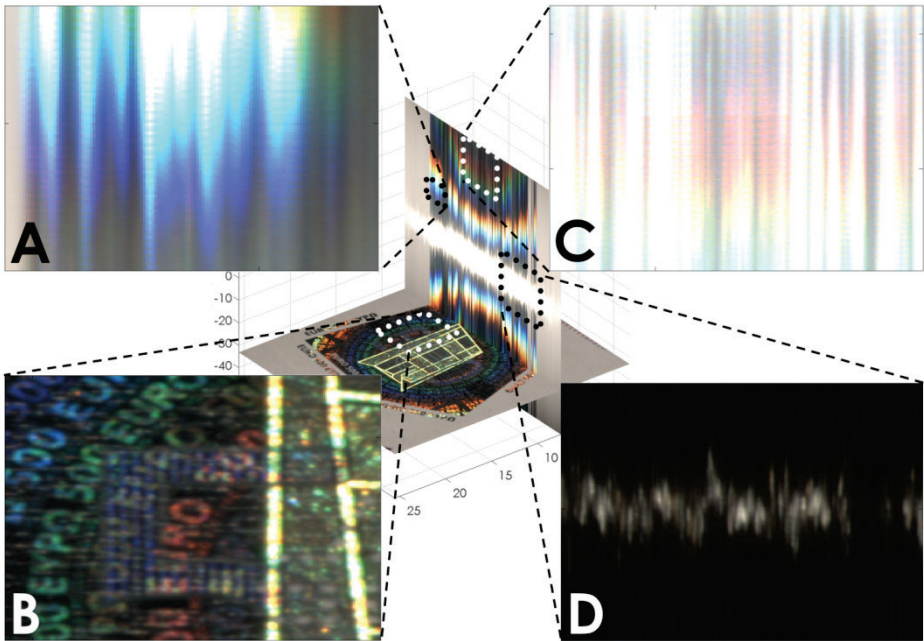

Figure 6 Zoom-in, in as well spatial, intensity as angle dimensions, of the trichromatic reflectance characterized, see text for details.

The illustrations stem from one same RV (i.e. not multiple characterizations e.g. adapted for different reflectance levels, etc.). A €500 Alphagram[®] is measured and the diffractive characteristics visualized. Sub-illustration A: angular dimension zoom-in. Sub-illustration B: spatial dimension zoom-in. Sub-illustration C: low reflectance (and angular) zoom-in, with a high amplification, it is possible to visually appreciate the color distortion and other noise to be low. Sub-illustration D: high reflectance (and angular) zoom-in, with a strong attenuation, it is possible to visually confirm non-saturation and appreciate a low noise level indicated by the graceful change in the tone values despite the high reflectance.

As the high resolutions of spatial and angular dimensions are in calibrated units of mm and degrees respectively, detailed visual observations may hence be attributed with these high accuracy spatial and angular coordinates.

Even spatially dynamic (“animation”) behavior may be visualized and characterized in static illustrations. Figure 7 illustrates an OVD of diffusely scattering moiré magnifier, “Motion”. The spatial translation of the graphics may be studied in detail as the inclined brown OVD graphics in the vertical plane. The angle information graphics (in red, green and black) inserted in the figure assists: the red dotted vertical line and green dashed line parallel to said inclined brown graphic features, forms the sides of an angle α . The translation may e.g. be characterized in units of motif translation per angle rotation [mm/degree], i.e. a spatial translation as a function of change in inclination (of OVD substrate in relation to the radiator/illumination and observer/detector).

As a comparison: a conventional spatially static OVD, e.g. a diffractive feature, would instead have had the brown OVD graphic motif in the vertical plane parallel to the red dotted vertical line. The diffusive brown color would also instead have been color-shifting.

Comment: The OVD measurement and characterization system presented in this thesis was first introduced in 2008 [7]. Although initially named (by others) “GonioLabs’ DOVID Reader”, GDR, the characterization is, as just described, not limited to DOVID OVDs as e.g. the physical principles like the diffusely scattering moiré magnifier of “Motion” is also within the characterization capabilities of the system.

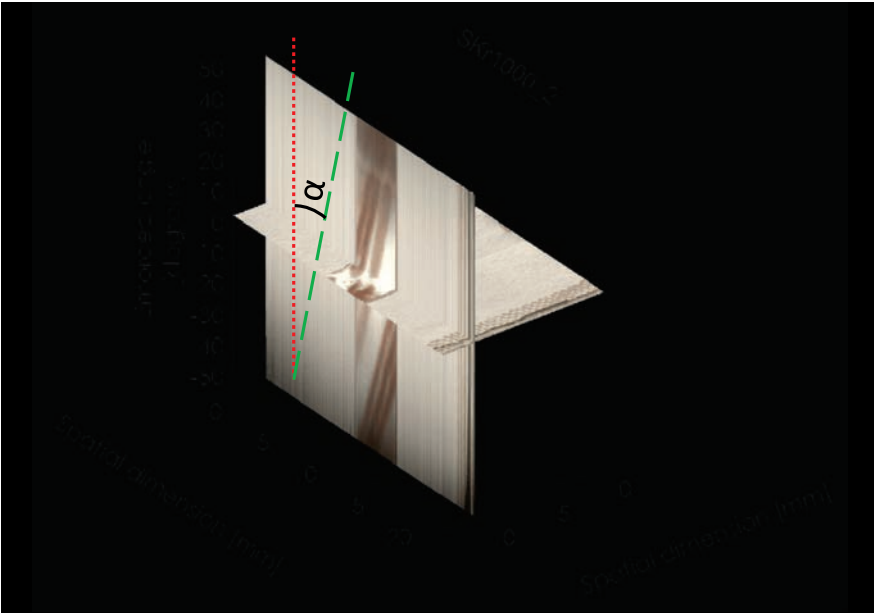

Figure 7 Spatial and angular representation of the diffusely scattering moiré magnifier “Motion” feature in the Swedish 1000 SEK banknote (issue 2006), see text for details.

7.2 Interactive visualization

The interactive visualization tool developed and implemented (**Paper III**) [4] operates on the RVM representation, i.e. the local facet approximation of the RV. This choice of information representation is of significance: “A critical issue in designing effective interactive systems is to find the minimum representation of a 3D object that does not compromise the visual quality of the object when it is rendered in two dimensions.” [41].

This visualization tool is a virtual reality (VR) software based interface facilitating the interactive manipulation of the surface to study the optical behavior of the surface in various angle dependent configurations relative to the illumination and observer. The virtual surface may be globally inclined, curved and translated (over the curva-

7 • Visualization of Documents

ture), all parameters controlled interactively and resolved in fractions of millimeters and degrees, see Figure 8.

The main section to the center-left is the visualization area. In the upper right-hand corner is a sample holder, on which the sample is placed. The controls for the sample holder are in the bottom right-hand corner. In the visualization area the appearances of, in this example, two samples are simultaneously simulated. The sample to the left is rated “best”, and the sample to the right is rated “worst”, in terms of perceptual evaluation of gloss variation among the samples evaluated. In this snapshot, the sample holder is curved having a small radius, and the shape of this holder is virtually changed during an inspection. Note that the side length of the visualization area is only 10 mm.

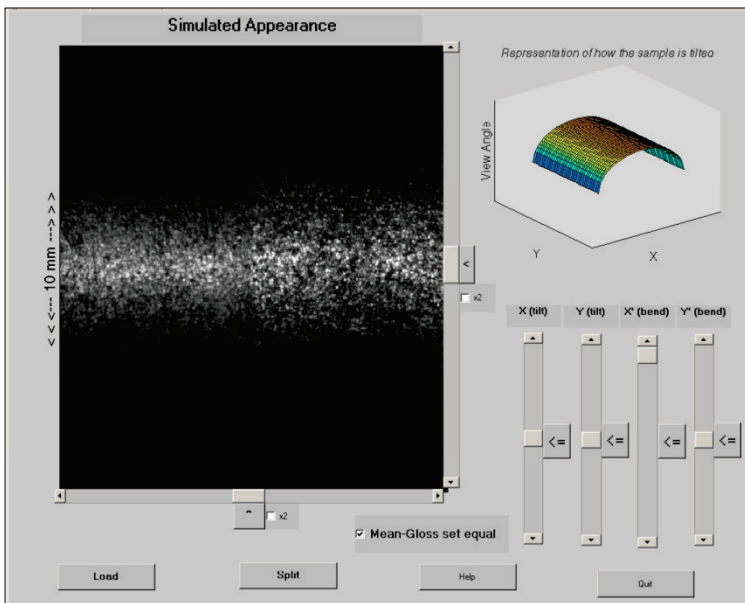

Figure 8 Snapshot from the interactive visualization interface.

Based on the response in the afterwards interviews regarding the man-machine interface and the user-friendliness, the VR software required only a short introduction before the judge operated the tool independently and fluently. Comment, the graphical layout may appear dated; the main reason is that the VR software was finalized in year 2001. Judges have described the interactive visualization as of high naturalness – a verdict of critical importance to achieve a state of “presence”, i.e. a mindset of the judge where she no longer pays attention of the simulation as such [42]. The related concept of “suspension of disbelief” is also used in this context. At the state of presence, the judge intuitively interacts the sample with the focus of attention is on the experience and evaluation of what is sensed as the physical sample. This verdict of naturalness is however only a necessary but not a sufficient criterion for a successful VR environment as the fidelity to the physical original sample must also be fulfilled.

The visualization fidelity to the original sample was evaluated by comparing evaluation results from original and simulated surfaces. Two independent sets of samples with challenging small inter-set differences were evaluated. The small differences within each set, caused the samples, including the physical samples, to be difficult to differentiate and rank, even for the most experienced judges. The results of the experienced judges based on the VR agreed overall well with the results based on the physical samples with similar degree of inter-judge variation. The response of the less experienced judges differed somewhat where the results based on the VR resembled better to those of the experienced judges than the results based on the physical samples. Hence these pair-wise comparison results indicated that the VR achieved a high degree of fidelity to the physical samples and that less experienced judges benefitted using the VR to achieve results in closer resemblance to results from experienced judges.

It is worth noting, the described results of the VRs abilities to mediate the optical behavior of also demanding physical surfaces, give credits not only to the visualization system but also of the gloss measurement system and the characterization into the RVM as the end result is critically dependent on each of these subsystems (**Paper III**) [4].

8

APPLICATIONS FOR OPTICAL DOCUMENT SECURITY

Chapters 3 to 7 have been focused on perception evaluation or product detailed characterization demands, and how the measuring, characterization and visualization systems are designed and implemented to meet these demands. The results presented so far may be seen as a basic tool-set for these delimited tasks described.

This chapter is instead application-oriented, defining the demands in terms of services or end-product functionalities, in the context of optical document security (ODS). These demands are generally complex, due in part to lack of crisp definitions of concepts and that the demands often have a character of process instead of a set (final) goal. Examples include a demand for a *sufficiently* counterfeit resilience during a *sufficiently* extension in time, e.g. for an expected product life-cycle. Even if such demands may be decomposed to some extent, the high dependence of latent (unobservable) variables, such as the capabilities of present and future counterfeiters, cannot be avoided in the demands. The challenge is hence not due to ill-defined goals but rather that the needs include influential uncertainties resulting in inherently difficult problems. Trivial, conclusive or final solutions are therefore likely illusions; a demanding circumstantial evidence based approach acting as a temporarily solution may be the best available option for such inherently challenging demands.

However, the previously described tool-set may facilitate the work in multiple-different and significant ways by addressing the core and inherent stumbling blocks of the problem. There may be reasons to believe that one such critical hurdle relates to the interplay between the characteristics of a perceptual evaluation and the angle dependent high dynamic range optical behavior of the product.

Sections 8.1 to 8.4 give preliminaries, describing the different classes of inspection, the current and potential inter-relation of the inspection classes, aspects of first line inspection, aspects of supplementary inspections for risk minimization and physically unclonable functions facilitating secure communication. These sections also cover descriptions of challenges, potentials and business needs. Then, in Section 8.5, a range of principally new applications are sketched aiming at these described challenges, potentials and business needs, and based on the measurement, characterization and visualization presented in this thesis.

8.1 Three inspection classes

Inspired by the standard reference [1] on the topic, inspection plays a decisive role in the effectiveness of security systems and may be divided in the following three classes:

1. *First line*: no tool, inspection normally performed by the general public;
2. *Second line*: tools like magnetic sensors, bar code readers, fluorescence detectors etc. aid the inspection performed in general by trained inspectors;
3. *Third line*: sophisticated laboratory equipment based investigations performed by forensic experts.

While first line inspection aims generally to detect most counterfeits (*falsification* – “to verify the fake”), the purpose of second line is to confirm the authenticity (*verification* – “to verify the genuine”). Tools for automatic detection, e.g. card authentication method (CAM) reading devices in ATMs are second line inspection tools. Third line aims to resolve doubts when second line is unable to give a decisive answer, and to produce facts in court (*jurisdiction* – “to verify the faker”).

Although first line inspection generally aims at only falsification, the OVD security feature is an important special case and the inspection may potentially be a verification process [1, 43].

Established security features are designed primarily for either first, second or third line inspection. Although rigorous state-owned laboratory third line equipment most probably can analyze and verify all security features of documents issued by the state, irrespective of intended inspection class, each given feature is aimed and designed for only one class or at least primarily one class. To achieve verification based on two supplementary inspection classes outside laboratories, i.e. based on both first and second line inspections, hence requires two different security features each targeted primarily for one of the two classes.

8.2 Factors of successful inspection

The purpose of inspecting, in the context of optical document security, is to decide whether the document is genuine or not. This apparent crisp and well-defined question is in real world application more elusive as a verdict is based on multitude of factors to be judged with, at the same time, disturbing factors to ideally ignore. In the following Subsections 8.2.1 to 8.2.5, factors influencing an inspection are described, some that may facilitate and others that may be detrimental a successful inspection. Generally, these described factors are not equally important for first, second and third line inspection. On the contrary, the individual classes have their specific set of most influential factors. Note also that the described factors may be inter-dependent, e.g. the ratio of (i.e. the likelihood of indeed performed) inspections may be higher for trained inspectors than the untrained general public, which complicates the methodology analysis but are nevertheless a set of valid and characterizing descriptors.

The described multiple dependent factor character of inspection motivates why decisive measure of effectiveness cannot be stated or expected. Instead, the best we can aim for are well motivated estimates based on described assumptions. In this con-

text we can relate a concept used by the US Secret Service: the phrase “passable product” is used to denote an item which may be fake but which has been accepted (passed) by a lay person or even a retail clerk [44].

Despite the complexity and slim chances for precise indisputable measurements, identifying significant influencing factor is important for estimating the robustness and improvement potential of inspection methodology. Such significant influential factors are described in the following.

8.2.1 Frequency and ratio of inspection

Traditionally banknote issuers have been reluctant to involve the general public in the checking of banknotes, preferring to rely on those employed to handle them, experts and machinery to authenticate the various (often undisclosed) features [19]. Relying on experts and machinery for authentication, a substantial ratio of transactions occurred without inspection. As long as the counterfeits were exceptionally rare, the low inspection ratio was not an important issue. But in the 1990s, this changed as the ability to counterfeit had moved from those highly skilled in printing to anyone with a scanner and computer – the incidence of counterfeiting grew exponentially in the then preceding decade [19]. The relative low ratio of inspections was now a critical problem and a principal change in inspection protocol was necessary. In order to mitigate this transition the general public had to become more involved in the inspection process to increase the inspection ratio. Since then the first line security is in general considered of high significance in counterfeit deterrence programs for banknote, travel documents such as passports and other security documents of significant value.

First line inspection has the desired feature of inspection during a high ratio of instances of document transactions although the actual inspection frequency ratio may still not be very high due to difficulties to motivate a sufficiently large ratio of the general public.

8.2.2 Informing and training of inspectors

The task of document inspection requires training or at least information about a “genuine message” – what to expect, what to possibly detect as anomalies and hence a possible counterfeit. Border Guards must have sufficient knowledge of the optical behavior of OVD in every Passport that may be inspected by the border control. Similarly, the general public is informed via various channels already before an upcoming banknote revision and the information is generally easy-available thereafter. The information is necessary in part to be able to fulfill the task, but also as an informed inspector is less likely to feel uncomfortable in the inspection process which influences the likelihood of indeed pursuing the inspection. An informed inspector is also more likely to undertake the task as seriously as motivated. This is a challenging question regarding the banknote inspection by the general public, but it may also be a challenge regarding professional inspectors, also for other high value documents.

The information and training is however difficult for a number of reasons. First a novel OVD design may be described generally which appears less helpful to the general public. However, information on specific descriptors that facilitate the communi-

8 • Applications for Optical Document Security

cation may also cause the design to be more vulnerable to counterfeiting, as matching these specific descriptors, for an otherwise less sophisticated simulation, lowers the required effort for the counterfeiter. In this case, the selected focused information facilitating effective communication results in an increased exposure to counterfeiting, i.e. a counter-acting activity. Another reason why information is a difficult problem is that this is often a one-shot campaign before the launch of e.g. a banknote, without followed-up revised information. If instead additional information may be delivered when necessary, during the product life-cycle, the general public can be up-dated and reasonably informed for the task.

Another challenge is, especially regarding the general public and first line inspection, the strong belief that no document is a counterfeit. Information campaigns are then ineffective, and inspectors will remain ignorant and inspections will remain infrequent, hence over-all ineffective inspections [44].

8.2.3 Feature conspicuousness

A first line security feature is ideally self-instructing, with graphic elements, iridescent and animation behavior all and by themselves facilitating the identification of the counterfeit resilient characteristic features. This self-inherent message of identity, or conspicuousness, is a highly desirable characteristic as it reduces the risk of an uninformed inspector and increases the ratio of inspection.

Although an OVD may be well designed to facilitate first line inspection, surrounding graphic layout in the security document may hamper the counterfeit deterring capability. Such deteriorating surrounding graphics may be due to attention competing decoration, cluttered design loaded with graphics of multiple contrasting colors or other reasons causing it difficult for the inspector to focus on the security feature without distraction.

Such conspicuousness deterioration may be avoided by considering graphic interaction design and ultimately, if in conflict with other design considerations such as aesthetics or similar artistic ambitions, give the security functionality the appropriate level of priority according to the security policy, program and requirements decided.

These ergonomic related security design and evaluation challenges are treated in-depth in the reference work by van Renesse [1], in turn also referring to a book by Donald Norman [45] (a revised and expanded edition) which also is a reference work in the fields of industrial, interaction and experience design of complex modern devices. This book [45] that may appear somewhat peripheral is on the contrary very relevant covering fundamental aspects of interaction (communication and exchange of information) between user and object, which is the essence of also first line inspection, and doing so in a most pedagogical and informative manner.

8.2.4 Falsifiers and verifiers features

As mentioned in Section 8.1, first line security features aim at least to be *falsifiers*, however more capable features achieve also the more demanding status of *verifiers* depending on the combined capacities of degree of counterfeit resilience and conspic-

ousness, when evaluated in first line inspection [24]. If e.g. the counterfeit resilience is only moderate causing simulation to be difficult but not unlikely, the feature is at best a falsifier able to confirm a counterfeit but not to ascertain a genuine document. At high enough counterfeit resilience causing simulation to be unlikely in combination with a high level of conspicuousness, the feature is a potential verifier, facilitating an evaluation of the authenticity, irrespective of the security feature is counterfeit or genuine.

While many first line security features are merely falsifiers, OVDs are categorized as verifiers [24]. This motivates the OVDs to be mandatory or recommended requirements in e.g. ICAO Travel Document Standards [46] and EU Travel Document Standards [47], documents of high personal and financial value. Comment: as of 2012 Keesing Reference Systems estimated that more than 55 percent of travel documents include OVDs. As of 2018 Passport Index™ (Arton Capital, Canada) ranking of visa-free scores, all the top-ranked and hence precious documents of Singapore, Germany and Sweden (and many others) include OVDs.

8.2.5 Feature endurance – deterioration due to circulation

A security document in circulation deteriorates the optical properties of an OVD, as dirt, wear, scratches etc. all cause a deviation from the original uncirculated OVD optical properties. If the authorities do not take appropriate measures to mitigate this problem, the inspectors valuing if the document is genuine or not will experience a wide variety of feature characteristics and gradually adopting and lower the threshold of refusal. The inspectors will hence accept also OVD showing a large deviation from the original uncirculated OVD. This puts the optical document security system at risk as it lowers the requirements for simulations to achieve a certain likelihood of the simulation being accepted as genuine document, c.f. the concept of ‘passable product’ in Section 8.2. Although the reasons for the security feature declining capabilities differ, the negative consequences due to lack of information and training and described in Subsection 8.2.2 are equally applicable for feature deterioration. The described risk is as relevant for e.g. banknotes for which the inspector is often a general public layman, as for travel documents for which the inspector may be a well-informed and well-trained national authority representative.

To mitigate the negative consequences, worn security documents should be taken out of circulation when below a defined acceptable performance, which requires monitoring. This rejection process, to be effective, requires the monitoring of a high enough ratio of security document transactions.

8.2.6 Technology advantage endurance – deterioration due to simulation advancements

The potential significance of the above described first line inspection are motivated only as long as the security features’ potential, e.g. as a verifier, remains. As every security feature is constantly and fiercely challenged by skilled and motivated counterfeiters, the fidelity of the best simulations generally improve over time for a given

8 • Applications for Optical Document Security

revision of genuine security feature. If these simulations improve to the level that “successful” simulation (c.f. “passable product” in Section 8.2) that used to be unlikely instead become difficult but not unlikely the former verifier security-feature degrades to merely a falsifier, able only to confirm a counterfeit but not to ascertain a genuine document. Continuing to rely on the security feature as a verifier would then be unjustified.

The described continuous increase of the aggregated ability of counterfeiters puts obvious demands for a continuous progress in the research and development process of security features and verification protocols. The security features must differ from the best simulations under the entire expected life-span of the security document. A failure to deliver the expected (“budgeted”) endurance of protection may cause a sudden and an urgent need for a premature revision and a corresponding major revision of schedules. Such scenario may involve not only a project financial premium but also the risk of cascading negative effects onto also the revised security feature, due to project high-pressure and non-conventional process procedures, short-cuts etc.

Therefore, the management of an inspection protocol relies on a) the budgeted first line security feature life-cycle extension, to avoid surprises and described corresponding negative consequences and b) the know-how and skillful technology development capacity to introduce novel security features at a phase motivated by the cost of not introducing novel security features. A balanced optimization considers at one hand the cost of counterfeit resilience security features and at the other hand the cost of counterfeits both directly in nominal values and indirectly in a possible questioning and ultimately disbelief in the currency system.

8.3 Aspects of supplementary inspections for risk minimization

Supplementary inspections can be an effective approach to reduce the likelihood of a negative outcome, i.e. a risk. Depending on the application needs and the purpose, the security protocol can be designed e.g. to judge the document genuine if at least one (minimize false refusal), or all (minimize false acceptance), or a ratio of the verifications pass the evaluation. This may significantly limit the targeted risk, whether it is a failure to accept a genuine document, a failure to refuse a simulation or another risk. The apparently straightforward and trivial risk minimization approach may however in real-word applications be intriguing. The outcome “at least one” may be considered different if the other tests fail to pass the evaluation, or if the other tests fail to perform the evaluation, i.e. are not conducted.

Also temporal considerations may be important. A security protocol may, after insightful considerations, accept a temporarily reduced level of counterfeit detection ability during a limited time failure to connect to the internet, in order e.g. to guarantee an upper limit for the response time, for every given limited time of internet connection failure.

The supplementary inspection approach do have pitfalls but essentially add principally new degrees of freedom that may be a powerful tool when designing and managing security protocols, which will be described further in the following.

8.3.1 Supplementary inspection pitfalls

Supplementary inspection is introduced at a cost. If the benefit is considered larger than the cost, the addition inspection is motivated. A supplementary inspection protocol is not given per se but often has degrees of freedom, and the cost and the benefit depends on the chosen inspection protocol.

Generally if the measurement (inspection) procedure suffers large levels of (uncorrelated) noise, the averaging of multiple identical or principally similar measurements reduces the noise and may thus be motivated. However, in such situation the initial large levels of noise motivate questioning of the inspection procedure and a revision of the procedure trying to improve the SNR may be a better option.

If the level of measurement noise is estimated low compare to the estimation of other inspection risks, such as a risk of simulations being successful in only a few out of many aspects for a genuine document, multiple identical or principally similar measurements do not significantly reduce this risk. This may be understood as the described supplementary inspections are correlated and therefore do not result in any principally new information and therefore no significant reduced risk. In this described scenario, the multiple inspections only give “more of the same”, without significantly added benefit.

Similar reasoning regarding single security feature versus set of features have been reported, noting that features are often but unfavorably dependent, hence adding features may in worst-case counter-act the intended counterfeit deterrent effect [43].

8.3.2 Supplementary inspection guidelines

For demanding or multiple-aspect tasks where the principal challenges of the measurement process appears only vaguely it may be favorable in terms of risk reduction to aim at dividing the task into a set of well-defined components. The idea is that the resulting multiple different-type of measurements and the remaining aggregation of the measurement results is less demanding than the initial task. With this approach the supplementary inspection effort is spent on performing multiple well-defined tasks. Inspection of security documents for potential counterfeits may be considered both a challenging and a multiple-aspect task. It may hence be motivated to aim for principally different supplementary inspections, not principally similar multiple inspections.

These ideas may again relate to studies of single security feature versus set of features, where a set of well-designed features can provide a layered defense against an array of counterfeiting threats [43].

8.3.3 Multi-modal supplementary inspection

Further relating to security features: general relying on a single dominant feature may provide false security, including machine-readable features [43]. For high value security documents, such as travel and identity documents, that mainly due to an enhanced risk of counterfeiting have been equipped with second line inspection authentication, e.g. software and circuit based challenge-response algorithms may be improved significantly if also introducing a first line inspection based verification of an OVD. This

8 • Applications for Optical Document Security

introduction of a man-in-the-loop limits the risk of relying on one feature only, a single line of penetration defense, by a) introducing a second-line penetration defense and b) choosing the second-line penetration defense technology to be different from that of the first-line. A counterfeiter must, to be successful, simulate this verification twin-set based on two different inspection classes (i.e. first and second line inspection) and these functions are also based on different technologies, and therefore require the expertise in two distinct areas. Such verification procedures requiring multi-class inspection or being based on principally different physics and technologies may be described as multi-modal.

8.4 Physically unclonable functions

Physical one-way functions [48, 49] and the less restricted and non-orthodox but for applications equally relevant physically unclonable functions (PUF) have in the most recent years grown rapidly in importance for information technology applications. Citing Maes [50]:

“...PUFs are innovative physical security primitives which produce unclonable and inherent instance-specific measurements of physical objects; PUFs are in many ways the inanimate equivalent of biometrics for human beings. Since they are able to securely generate and store secrets, PUFs allow us to bootstrap the physical implementation of an information security system.”

Although the theoretic fundamentals of PUFs are well-established, every realization is challenging. PUF realizations are based on one of a variety of physical principles including: a) random process variation of silicon chip production e.g. unique time-delay based variations, bistable memory elements and the resulting random state variation (“memory based”), and mixed-signal including an analog-to-digital conversion quantization; b) optically based speckle pattern from laser interaction with randomly distributed scattering particles; c) electromagnetic based capacitance between silicon chip twin-wires where the chip surface having a randomly distributed layer of dielectric particles (“coating PUF”) [51, 52].

Irrespective of physical principle involved, the applications of PUF generally rely on a sequence of fundamental inequalities of characteristics. The construction of PUF may be controllable down to a certain level of characterizing detail but (a) not beyond this level at which the construction introduces uncontrollable characterizing detail³. The PUF verification function is able to verify characterizing details beyond the described resolution limit (a) of the construction process and – ideally – giving the characteristic features above said resolution limit (a) an appropriate level of significance, as these larger-scale features are controllable, potentially cloned and otherwise cause the verification process to be less selective. These inequalities are easily motivated and despite likely realization intricacies involved, may be achievable. However, to give a formal and rigorous proof of these inequalities, for any realization, is not known to the

³ Cf. *security-through-obscurity*, where the secrecy can be reproduced but relies on trust, where PUF security instead relies on short-comings of general knowledge, technology and possibly nature of physics, defining the construction barriers.

author although the topic is given extensive treatment in the literature. In the absence of proof: for intricate and established products where extensive resources are spent to eliminate, or reduce, or control product variations, the residue uncontrollable variation may be prohibitively expensive to remove and even more expensive to utilize in a controlled manner for cloning purposes. “Even with extreme control over a manufacturing process, no two physically exactly identical objects can be created due to the influence of random and uncontrollable effects.” [50]. In essence, necessary (however not sufficient) criteria for a PUF include a physical feature of large address space (degrees of freedom) that is not controllable during construction (initiation) and a characterizing measurement system sufficiently well matching this address space to be able to verify them, at a sufficiently high SNR.

Such PUF defining static (not varying after production) but randomly introduced (beyond the control of the production facility) features are obviously related to the reproduction resolution limits but also to the measurement resolution and measurement noise floor. The features may hence be defined as a random process and characterized in terms of (channel) entropy. In fact, in the book by Maes [50], the concept of entropy is vital tool to explain and analyze PUF performance, both to describe fundamental theoretic concepts but also to give performance estimates of physical world realizations (where exact figures are often impossible or at least very difficult to give).

When basic physical security requirements of the PUF is achieved and certified, well-established cryptographic primitives (in extensive everyday use, e.g. in safe customer-bank-communication over (the unsecure) Internet) are applicable. Such cryptographic primitives include unkeyed (hash functions), symmetric key and public key primitives. Having the essential cryptographic primitives established implies that also high-level information security technologies are applicable [50].

PUFs may be classified as *intrinsic* or *non-intrinsic*, based on the physical construction properties [50]. In an intrinsic device, the evaluations are performed internally by embedded measurement equipment. With few exceptions, PUFs are of type intrinsic, using a variety of principally different features as a characterizing aspect of the algorithm but in general realized within an integrated circuit silicon chip. Although convenient having the authentication functionality as an integrated system, one disadvantage is that the intrinsic PUFs must be trusted as it is virtually impossible to externally verify the internal evaluation [50]. Non-intrinsic PUFs, one example being the above mentioned optically based speckle pattern based PUF, may be designed to facilitate such external verification. For these non-intrinsic PUF it is not necessary to trust them to achieve the desired functionality, which may be a significant advantage for certain demanding security applications.

8.4.1 OVDs of PUF potentiality

OVDs are most often used to identify a group of documents, such as a banknote of given denomination or a passport issued by a certain country authority. Then all instances within the group are ideally identical and no effort is spent to identify possible differences between (genuine) OVDs at the inspection. Even for the rare cases of unique OVDs, the individual and differentiating information is introduced under the controlled production phase. Hence OVDs can be described as a deterministic repro-

8 • Applications for Optical Document Security

duction, especially so as the reproduction accuracy is generally superior to the evaluation (characterization) system accuracy. This accuracy inequality may be understood as OVDs are evaluated by the human visual system with inherent inferior capabilities in terms of absolute level accuracy, reproducibility and similar absolute meter characteristics. Therefore, in this case the described sequence of inequalities in Section 8.4 necessary for a PUF is not fulfilled; hence OVD inspected by a human only, is not an operable PUF system.

However, a calibrated and more capable optical measurement system, surpassing the human based inspection performance, and able to characterize features beyond the resolution limit for which the reproduction facility deliver a well-controlled output will capture also product random and individual features. This opens for principally new applications.

Characterizing also these fine-scale features beyond the control of the reproduction facility not only adds product feature fidelity but is a benefit of principal importance as it causes the described sequence of inequalities in Section 8.4 necessary for a PUF to become fulfilled; hence OVDs are under these condition a potential PUF.

8.5 Principally new applications for OVD in security documents

The accurate and reproducible measurement, characterization and visualization methods, operating the significant aspects of first line security features is a principal achievement based on the methods described in this thesis. These methods facilitate a range of applications relevant for the optical document security business that have not been presented by others in the literature. In the following, a selection of principally different such applications are presented. It may be noted that these following subsections address many of the challenges and potential features described so-far in this chapter.

8.5.1 Standardization of security feature specifications

Relevant but challenging questions like: “What specifications should the OVD deliver, in terms of optical, spatial and angular dimensions, to meet our needs?”, “What are the tolerances to be met?”, “What should the supplier deliver?”, “What will be tested to verify the product characteristics.”, “What is an acceptable degradation of product characteristics, due to circulation?”, and other similar questions may be treated more rigorously based on the methods introduced in this thesis. In fact, the ability to calibrated measurements of spatial, angular and spectral radiance characteristics of OVDs opens for definitions of product specification standards.

A note: standards come with a cost and deliberately impose other development restrictions [45]. Well-designed standards are however cost-effective imposing restrictions based on fundamental principles that ideally will not change over time. Standards defined on end-user characteristics are more likely to promote product development, compared to standards defined by product characteristics. The former desired standards would for the security industry then be defined in the terms of the

8.5 • Principally new applications for OVD in security documents

perceptually significant characteristics of OVDs, requiring the more capable measurement, characterization and visualization methods introduced in this thesis.

At this higher level of ambition the described methods also facilitate specifications defining classes of security features in terms e.g. of smallest details allowed in graphic layout, maximum angular contrast (“change in appearance per degree of inclination”) as well as sufficiently complex optical behavior. These classes of specifications, further utilizing the characteristic abilities and restrictions of the human visual system, are as relevant for already realized products as for possibly not yet invented optical-based technologies or not yet realized OVD products. Such classes of specifications, or meta-standards, may guide to both simple enough features to facilitate the detection, and complex enough features difficult to simulate, that may guide and thrive future revisions of OVD more than would a conventional-type standard. These meta-standards should be as permissive as possible and restrictions imposed motivated by the capacities and limitations of the human visual system. Such meta-standard may spark the industry for new innovations.

These described standards and meta-standards further open for a more effective and efficient communication between actors e.g. of a procurement processes and product development.

8.5.2 Structural design and verification process to ascertain the conspicuousness of novel security features

The conspicuousness of first line security feature is, as described above, important. The development of novel security features having this desired characteristic may be facilitated by the system introduced. The optical behavior and the conspicuousness may be approximated based on a) characterizations of the perceptually significant optical behavior of the feature, b) the Modulation Transfer Function of the human visual system, and (optionally) c) sub-optimal evaluation conditions. The motivation for the optional c) may be a desire to design a feature having a performance margin in the case of sub-optimal evaluation conditions (dim light, pencil-beam illumination etc.), visually impaired e.g. color blind evaluators etc. Such ability to approximate the conspicuousness of a first line security feature in various conditions may be of significant importance e.g. when verifying the security potential of a novel feature.

The described abilities facilitate basic criteria for a verification procedure to ascertain that the desired optical behavior is indeed met.

8.5.3 Communication protocol for optical document security management

Strategic counterfeit resilience is dependent on an effective and efficient security feature development process that meets quantifiable goals at a foreseeable cost and meeting the time-schedule. This apparent self-evident desired approach on e.g. banknote revisions is however not a general and common practice [53]. However, strong arguments for the concept of “Program of Requirements” (POR) to support and promote

8 • Applications for Optical Document Security

the described work process during a banknote revision, have been stressed by influential parties [1, 43, 53].

A measurement device with appropriate, established and well defined characterization performance, able to quantify the perceptually significant optical behavior opens for well-defined product requirements regarding e.g. non-circulated (fresh) banknote performance criteria, circulation endurance criteria, acceptance criteria – overall facilitating procurement and business contract formulation. These capabilities facilitate the formulation of POR and hence multiple challenging and potentially time and other resource consuming process activities through the entire security feature development life span, including formalization of an appropriate communication protocol.

Such POR and communication protocol for optical document security management providing indisputable relevant measures reduces the risk of misunderstandings and business conflicts that in turn result a more as well effective as efficient optical document security management.

8.5.4 Monitoring security feature degradation due to circulation

The ability to measure and characterize security feature degradation due to circulation has been clearly illustrated also in relation to HVS capabilities (**Paper VI**) [7] and further quantified in terms of chromatic and angular specificities (blur avoidance) (**Paper VII**) [8]. The functionality may be used for monitoring and collecting multiple-aspect performance statistics including simple scalar characteristics: mean, median, variance but also more compound information on percentiles, outliers etc. with a high degree of explanatory power and specificity with respect to first-line inspection optical performance. Such capabilities is desired e.g. in product development or formulation Program of Requirements during a security document revision process. Even more important, the capabilities may be used for a pass/rejection decision maintaining the optical performance of the security documents in circulation on a high-enough level.

An instrument-based autonomous monitoring system able to characterize every document that passes through the instrument may contribute to achieve an over-all high ratio of inspections (c.f. Subsection 8.2.5). If further the instrument based outcome of the pass/reject decision is well-tuned and in agreement with what is relevant for a human based inspection the instrument may be a vital tool ascertaining a high enough level of optical performance of the OVD features, of the security documents in circulation.

8.5.5 Monitoring fraudulent attempts and inspection maintenance needs based on multi-class supplementary inspections

The performance of a security feature depends not only on its resistance to fraud but also on its capability to unveil the fraudulent attack [1]. The methods introduced in the

8.5 • Principally new applications for OVD in security documents

thesis facilitate multi-class supplementary inspections and hence new possibilities for rigorous architectural design of novel inspection protocols and improved capabilities to detect fraudulent attacks.

Multi-class supplementary inspections of one same OVDs security feature may be desirable e.g. to limit the number of security features of the hosting document. With other priorities multi-class inspection of one security feature, may cooperate with other machine or human inspector based covert, semi-covert or overt other security features to achieve the desired counterfeit resilient inspection protocol.

Another principally different protocol may instead monitor the relative performance of inspection processes to detect e.g. a gradual or disruptive change in relative performance as an indication of problems, and hence need for maintenance, in the inspection processes or an indication of the inspected OVD being fraudulent. Examples include: a) first-line inspection facilitated detection of a hacked software-based second line inspection, a second-line feature that would otherwise remain unnoticed; and b) second-line inspection facilitated detection of simulated (fraudulent) first-line feature, identifying the need for staff periodic recapitulative education to more effectively evaluate the first line features.

Note, as OVD are indeed multidimensional and challenging to simulate, also high-fidelity simulations may well cause a change of relative performance of supplementary inspection classes compared to the corresponding relative results for the genuine OVD, which facilitate the detection of counterfeits.

This ability of multi-class supplementary inspections of one or more security features adds new monitoring capabilities that promote OVD product development strategy and optical document security management.

Such described new capabilities work in concert with strategies of resilience engineering, to reduce the risk of also unforeseeable challenges and attacks [45] as supplementary inspections may add motivated and desired inspection redundancy.

8.5.6 Structured documents revocation process

A successful implementation of security feature degradation monitoring, opens also for selection criterion of the type: “fit for further circulation” and “too worn and teared, should be taken out of circulation”. Depending on the type of security document the decision consequences may differ. Individual banknotes may if decided appropriate action be exchanged, set aside and thus taken out of circulation at the time of monitoring. For personal identity documents such as passports however, the authorizing organization may instead be informed so that they can take adequate actions, e.g. informing the identity document holder to renew the document as the current document will cease to be valid within e.g. 30 days due to wear and hence failure to meet necessary performance criteria.

The described assumes the document judged genuine but too worn. For documents judged as a counterfeit may or may not need alternative measures, depending on the revocation process decided. The methods introduced support also such strategies.

8 • Applications for Optical Document Security

This structured and objective process to automatically take inferior security documents out of circulation would facilitate maintaining the optical and appearance performance of the documents in circulation above a chosen threshold. This functionality is of high relevance in the management of security documents.

8.5.7 Physically unclonable function

The performance of the measurement methods introduced surpasses the performance of the controllable features resulted by the OVD production process of products thus far characterized. In one aspect, multiple instances of OVDs that ideally would be identical are accurately and reproducibly characterized as distinct, i.e. these production uncontrolled features are measurable. Multiple evidence of these claims are given e.g. in (**Paper VI**) and (**Paper VII**) giving characterizations of the inherent chromatic variation of regions intentionally of constant chromaticity, surface structured caused optical response undulations where optical undulations should not be caused by surface structure, etc. Huge resources from the most resourceful organizations are spent to avoid or at least to minimize the described imperfections. Nevertheless the imperfections are obviously present. These so-far unavoidable imperfections may however be essential features facilitating a physically unclonable function (PUF) security protocol. Remaining challenges include the verification of feature stability e.g. regarding circulation, a feature degeneration must either be small enough or possible to model or adapt to (by the verification system) to be effective. The handling of feature degeneration is a well-researched topic for other technology PUFs which ideas and solutions may well be applicable or generalized to also OVD based PUFs.

To detail the capabilities of the measurement methods introduced, in relation to the OVD products thus far characterized, further: The dynamic ranges and resolutions of the dimensions (channel capacity or channel entropy) of the introduced methods surpass the corresponding dimensions (channel capacity/entropy) under control in the OVD production process.

The above and Section 8.4 including Subsection 8.4.1, are together strong arguments for the potential of OVD based PUFs. The reader interested to further evaluate the soundness of these claims may found literature on unified security models for PUFs [52] and in-depth evaluation procedures [51], both to facilitate generic (non-specific) analysis of PUFs, of relevance. Also, an ISO working draft (IEC NP 20897) may also be or become of relevance.

8.5.8 Facilitating jurisdictional communication

The methods presented open for detailed studies of counterfeits facilitate jurisdictional communication. Citing the late authority van Renesse's analysis of the methods introduced in this thesis: "Unambiguous Forensic Communication; Such visual overviews and the additional exact XYZ readings could also facilitate unambiguous communication between forensic laboratories, which in turn could be of interest for the clear presentation of facts in court." [54].

8.5.9 Tamper resilient communication infrastructure

The RV capabilities including high spatial and angular resolutions, high dynamic range color sensor with high signal to noise ratio represents a massive information set, c.f. the concept of entropy in Section 2.2. As a descriptor of verifying the product as genuine only, the RV is overly redundant. Although redundant in this specific aspect, however with information significant to characterize other relevant and more intricate aspects of the security feature. This, in one aspect redundant information, facilitates a tamper resilient communication infrastructure. As already a small well-selected fraction of the total RV is sufficient to distinguish a genuine from a counterfeit, a challenge-response protocol is possible. In this context the challenge response pair corresponds an optical stimuli exposed on the document and the optical response detected. Hence, the exhaustive and fully characterizing RV need not be transmitted and exposed over a possible uncontrolled communication channel, only a fraction and disposable (to be used only once) challenge response pair.

The redundant characterization opens for other significant application such as a) an inspection instrument model dependent protocol, and b) authentication of un-known documents. In a use-case, a client instrument (C) may ask the trusted server (S) for a challenge given that (C) is an instrument of say model-X. S provides an appropriate model-X challenge which (C) applies as an optical stimulus on the OVD document and the response detected by (C) is sent back to (S) that replies a verdict genuine/counterfeit. In this example verification is made for an instrument of a certain verification capability (associated with model-X) without exposing sensitive information over a possible untrusted channel. Note here that no a-priori knowledge about the OVD document is needed in the client instrument (C), facilitating an inspection rig able to operate on all future security documents within its measurement capabilities. This is possible as the detailed full optical characteristics is stored at the trusted server (S) and the only information required for authentication is communicated as a challenge-response-pair supplied only on a need-to-know basis. (Some communication details are intentionally left out to avoid cluttering the description, including details like an expiring time-stamp for the challenge response, and hashing of communication messages etc.)

Verification instruments without internet connection or challenged by an unstable connection may, if desired, be supplied by a protocol defined limited set of challenge-response pairs stored in the instrument. This facilitates a continuous verification operation without the need for a continuous internet connection and without having a large volume of semi-sensitive information in a potential hostile environment, that would potentially otherwise compromise the security infrastructure.

The sampling protocol of monitoring devices, e.g. for wear and tear due to circulation, should be designed with consideration, otherwise it may be exposed to a risk of eavesdropping. By adopting either a fixed and restricted, or a pseudo-random sparse-sampling strategy, the information-set sampled may be in this respect desirably reduced. Thereby the information-set may be thorough enough to maintain the ability to estimate the degree of wear however with a neglectable risk of revealing characteristics of the OVD of any use in an authentication procedure. Such restricted information set may be sampled and communicated over also moderately controlled communica-

tion channels without challenging the overall security infrastructure. A strict “message use-once protocol” (confer “challenge-response”) for this communication may be used over an open (non-secured) communication channel.

8.5.10 Improved tamper resilience based on mutually dependent multi-modal technology verification

One aspect of the methods of measurement, characterization and visualization of ODS OVD presented in this paper, is the analog-to-digital (A/D) and digital-to-analog (D/A) transformation abilities of the perceptually significant optical characteristics at high dynamic range and high SNR. This has principal implications as it transform the analog physical entity of an OVD to a high-fidelity digital source of a message. Thereby signal theory with its plethora of capable and well-established analysis and processing tools is at hand, including information theory, as indicated in Sections 2.2 and 2.3.

The described transform facilitates not only the multi-modal inspection capabilities described in Subsection 8.3.3, where the individual modes are evaluated separately, but open for also more sophisticated multi-modal integrated communication schemes. Examples include an OVD response (message) as initiated by a set of spectrally steerable irradiators for a code generated by a public key infrastructure (PKI) challenge-response cryptography integrated circuit transmitted message. Note the integrated different modality communication. Such multi-modal capabilities facilitate the well-architected and well-engineered integrated system, as it inherently has multiple degrees of freedom. This may e.g. be to find a desired optimized middle-way of level of security and response/functionality robustness, under the priority set by the security policy, security program and requirements decided, for the mutually dependent multi-modal technology verification security system.

In one other aspect of this AD/DA-transform, the OVD-based digital message may be integrated or otherwise cooperate with block-chain functionality, aggregating knowledge of historical transactions either for tractability or for other verification purposes. This is another instance of such a mutually dependent multi-modal technology verification security system.

9

SUMMARY OF ORIGINAL WORK

This chapter will summarize and point at the main achievements or contributions of the papers included in the thesis. For the work co-authored, see Section 9.8, the thesis author's contribution is specified, Subsection 9.8.2. This chapter concludes with inter-sectional challenges and achievements not described in the individual papers but relevant for the measurement, characterization and visualization capabilities of the overall integrated system.

The topics discussed so far in this thesis have been application-oriented, aimed at answering the question: In what way can the knowledge and novel capabilities developed meet either phrased business needs or un-phrased significant challenges of the business?

In contrast, this chapter will focus on technological or methodological achievements aiming at characterizing the knowledge and novel technology capabilities developed, in contrast to the body of knowledge and already established capabilities. This characterizing information is beneficial not only to isolate the momentarily and explicit contribution of this thesis but also to help value the potential for and significance of this contribution, e.g. in terms of future or generic (multiple-instance) applications not explicitly described in this thesis.

Chapter 9 aim to give credibility to the previous claims of applicability, by pointing at summaries of technical and performance benefits based on published peer-reviewed works, authored or co-authored by the thesis author.

9.1 Instrumental Gloss Characterization - In the Light of Visual Evaluation: A Review (Paper I)

This review paper identifies principal differences between on the one hand published and established instrument based gloss evaluation methods and on the other hand perceptual based evaluations. Suggestions are given for critical changes needed to achieve results of the instrument based evaluation methods that better match the results of a panel of experienced judges.

Gloss is a significantly important appearance characteristic and hence of high relevance during visual perception evaluation. The concept of perception related gloss is however complex covering multiple aspects such as smoothness (homogeneity) at

9 • *Summary of Original Work*

various spatial scale spaces. Gloss is further a principal characteristic feature within the business of graphic paper and board, in terms of e.g. quality (preferences) and readability (absolute detectability of information). Gloss is however a far more complex visual concept than the established and standardized instrument-based gloss characterization methods are able to characterize. The instrumental analyses are either highly over-simplified (standard gloss meters) or over-simplified but with results still difficult to interpret (goniophotometry). The dimensionality and power of the directed reflectance information measured by existing instruments and standards are lower and less expressive than the information gained from a direct visual examination of a surface; existing tools are hence approximations that omit critical factors lacking significant explanatory power.

9.1.1 Contribution

The review points at century-old research that due to the slow progress in the field is still relevant, albeit not a sufficient body of knowledge to meet the needs of instrument-based characterization.

The significance of the review paper is the coherent overall description of critical differences between visual perception-based gloss and instrument-based gloss characterizations. The work identifies the research gap needed to be reduced in order to achieve gloss characterization standards and instrument-based characterization methods that significantly better approximate results of a panel of experienced judges evaluating the perceptually relevant aspects of gloss.

In the context of improved instrument-based methods, the following notes are further made:

1. The significance of the distinction between specular angle (SA), i.e. the angle equal and opposite to the angle of incidence, and peak angle (PA), i.e. the angle at which the directed reflection has its peak value in gloss characterization of paper and print, see Figure 9.
2. The high dynamics (high contrast) of the spatially resolved intensity in the reflection from a surface normally related to gloss implies that spatial frequencies in a range of also low sensitivity according to the contrast sensitivity function of the human visual system may be relevant.
3. Arguments for the many century old facet model, at times heavily criticized, as appropriate approach to describe the most significant dimensions of optical behavior of the surface tested, influencing a visual perception based evaluation. The facet model may thus be an inspiration how to improve instrument-based evaluation.
4. The significance of perception based gloss evaluation being a multi-dimensional characterization including non-specular (non-peak angle) features like the degree to which surface reflections can be excluded from the viewing angle is underlined. This is suggested in the literature as a more direct measure of gloss already in the year 1970 [18] but detailed and motivated further by the thesis author in the review paper. An instrument of high explanatory power must hence

9.1 • Instrumental Gloss Characterization - In the Light of Visual Evaluation: A Review (Paper I)

access and assess a similar multidimensional feature-set as evaluated by a human judge.

5. A measure of gloss, in relation to print and gloss quality, should consider at least two parameters: a) the mean level and b) the variation. The mean level should preferably be characterized in the peak angle. The variation can be split into two aspects: b1) the spatial dimension, or coordinates, and b2) the angular dimension. The spatial dimension provides information about reflectance variations as a function of change in x- and y-coordinates, i.e. different locations, over the surface. The angular dimension provides information about variations as a function of inclination of the sample.

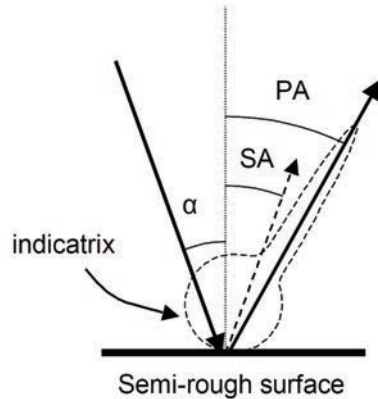

Figure 9 Illustration of specular angle (SA) and peak angle (PA) of a semi-micro-rough surface (e.g. a conventional unprinted office paper for printers). The indicatrix illustrates the degree of reflection at different outgoing directions, for a given angle of incidence. The SA equals the angle of incidence (α). The directed reflectance may be considerably lower at the SA than at the PA.

9.2 An Angularly and Spatially Resolved Reflectometer for a Perceptually Adequate Characterization of Gloss (Paper II)

A novel measurement principle for gloss characterization was developed and a measurement rig was built in a preceding master thesis work [11], to give more comprehensive gloss information, which at the same time has an intuitive interpretation. The integrated optical system is compact and has illumination and imaging receptor devices in fixed positions, which facilitates a mechanically simple realization. The instrument is a spatially resolved goniophotometer, albeit restricted to a constant angle between the illumination and the receptor. The measurement yields the introduced “Reflectance Vector Map” (RVM) which is an approximate achromatic optical equivalent to the surface measured. The RVM simultaneously contains spatially resolved information about directed reflectance and surface apparent inclination. The resolution is

9 • Summary of Original Work

high in both spatial and in angular coordinates. This provides a comprehensive massive data set, which when appropriately visualized show a high degree of fidelity to the visual properties of the original physical surface gloss and therefore encourages further evaluation and interpretation.

A homogeneity index called “Gloss Angle Smoothness” (GAS) was introduced, derived from the RVM, by weighing assumed perceptually “positive” and “negative” components of gloss. The index correlated well with results obtained by a panel of experienced judges asked to rate gloss homogeneity for the series of black printed paper tested, despite the series being challenging having only minimal inter-sample differences. The GAS index performed in this respect considerably better than a panel of inexperienced judges, relative to the results of the experienced judges.

9.2.1 Contribution

Novel aspects of the paper include:

1. The gloss measurement principle introduced, realized and verified, has the gloss sample snug-fit mounted on a cylindrical shaped sample holder and images the sample multiple times with inter-leaved incremental rotations. These increments cause the change of inclination of a given sample coordinate to be small and controlled, and executed relative to the illumination and the camera configurations. Retransforming cylindrical shaped sample projection spatial distortion back to a Cartesian metric concludes the angularly and spatially resolved achromatic reflectometer method.
2. The resemblance of the measurement principle and the data thus characterized, with often-adopted evaluation procedure of experienced judges, potentially measuring the significant resembling dimensions influencing the verdict of an experienced judge.
3. The characterization principle being able to distinguish “peak angle” (PA) from “specular angle” and base the further evaluation on the most favorable of them, e.g. PA in the case of an approximation of the results of a panel of experienced judges.
4. The characterization principle being general enough to provide data for further investigations of perceptually important and intricate off-specular aspects: at what rate do disturbing glare effects from a print decay as a function of inclination deviation from the peak angle (or “at how large angle do I need to incline the document to avoid perceptually disturbing glare effects”)?
5. The characterization principle being general enough for localized (patch-based) evaluation of e.g. printed and non-printed areas, describing specular and diffuse behavior separately.
6. The introduced reflectance vector map (RVM) facilitating a reduction of the massive data set scanned while still bearing perceptually significant optical characteristics of the gloss behavior of the surface measured. Motivations are

9.2 • An Angularly and Spatially Resolved Reflectometer for a Perceptually Adequate Characterization of Gloss (Paper II)

given for the RVM to be an approximation of an optical equivalent to the surface measured.

7. The introduced gloss angle smoothness (GAS) being an estimator of gloss homogeneity as evaluated by a panel of experienced judges. The GAS-evaluation being based on a fuzzy rule operating on facets apparent inclination, and the facet relative reflectance.
8. The performance of the realized measurement principle being evaluated relative, and in good agreement, to results from a panel of experienced judges performing visual perception based evaluation of gloss variation.

9.3 An Interactive Gloss Visualization Environment - For Measured or Simulated Surface Data (Paper III)

This paper introduced and realized a rudimentary model of a virtual optical environment based on the RVM, facilitates an interactive visualization of a surface measured. The performance of the visualization environment was evaluated by comparing results from two visual assessments of perceived gloss homogeneity for a series of black printed paper surfaces. The series were challenging to evaluate having only minimal inter-sample differences. Assessments were performed both of the physical surfaces, and of the computer facilitated interactive visualizations of the same surfaces, reconstructed from the corresponding RVM's. The two mean results correlated well, and with a less inter-judge variance in the results based on the visualization environment than the results based on the physical surfaces.

Besides the described performance measurements, a general comment from the judges was that, after only a few minutes of introduction to become familiar with the visualization system, the simulated surfaces showed a high fidelity and low degree of artificiality. The judges described a sense of evaluating the physical surfaces, notably however with an enhanced control of the samples and thus an ability to discern even small inter-sample differences. The sense of evaluating physical surfaces, in spite of their being computer simulated, is a very positive testimonial to the simulated environment. What was achieved is within the area of Virtual Reality described as a desired state of "presence".

It was suggested that this visualization environment may be a powerful tool for gloss assessment, able to mediate perceptually important characteristics of gloss.

9.3.1 Contribution

Novel aspects of the paper include:

1. The interactive gloss visualization principle based on the RVM introduced and realized being able to simulate perceptually significant aspects of the gloss appearance of the surface.
2. The gloss visualization environment further facilitates:

9 • Summary of Original Work

- a. a visual assessment of the simulated appearance, in the paper, of a non-trivial set of surfaces evaluated on a screen yielding results in agreement with a similar evaluation of the physical surfaces;
 - b. an intuitive operation as commented by the majority of judges, the simulated surfaces were perceived to have a high fidelity and naturalness, i.e., a sense of evaluating the physical surfaces (“a state of presence”), and with an enhanced confidence when discerning even minute differences of especially the most similar sample-pairs (thus enhancing e.g. the reproducibility, however not presented in the paper);
 - c. more uniform inspection conditions among judges during an evaluation;
 - d. the control of the surfaces under high angular and spatial accuracy, during inspection, which is of especially high value evaluating surfaces showing only small differences;
 - e. the elimination of the risk of judge caused damaging of the surface while handling it, during evaluation. This is a challenging problem for assessments having a large number of panel members and (unique) physical surface originals. An unconscious fingerprint grease mark on a surface may have a significant and irreparable impact on a gloss sample surface appearance;
 - f. distributed evaluation, where the judges are not limited to a specific geographic localization.
3. The perceptual evaluation results based on the simulated appearance in agreement with the similar based of the physical samples implicitly gives credibility to:
- a. the measurement system;
 - b. the characterization into the RVM as an information representation model;
 - c. the visualization environment.

Note that the credibility should be addressed as well the operations a), b) and c) individually as a-b-c jointly because each of these operations is individually critical links in the evaluation chain mediating the perceptually most significant gloss features while at the same time avoiding the introduction of system-caused appearance artifacts, i.e. features not stemming from the original samples. This is indeed a demanding task for a series of non-trivially evaluated samples having only minute differences.

If already one of the operations a)-c) would fail to meet the demanding requirements the evaluation chain would have been broken.

9.4 Sensor Interpixel Correlation Analysis and Reduction: a Review (Paper IV)

This review paper details the sensor interpixel correlation (IC), i.e. pixel-value leakage into neighboring pixels, which is caused by e.g. crosstalk, blooming or smear, see Figure 10. IC lowers the Modulation Transfer Function (MTF) of imaging systems, increases color distortion in color filter array sensors, is challenging to mitigate and generally overlooked. Recent scientific grade sensor findings (“the brighter-fatter effect” for CCD and “interpixel capacitance (IPC)” for hybrid-CMOS) describe a non-

9.4 • Sensor Interpixel Correlation Analysis and Reduction: a Review (Paper IV)

linearity where the IC varies with pixel charge accumulation. This is of relevance also for industrial and commercial grade imaging sensors. High dynamic range imaging (HDRI), deliberately operating the sensor in also saturation which add to the IC, is consequently especially susceptible to IC. Well-established HDRI algorithms exclude saturated pixels but generally overlook IC.

The paper further identified and motivated the need for a generalization of the Point Spread Function (PSF) into the suggested irradiance-exposure dependent (IED) PSF, including also super-saturation. Although challenging to characterize and apply, in part due to the non-linearity, the IED PSF will potentially facilitate MTF improvements irrespective of image sensor technology used and regardless conventional or HDR imaging.

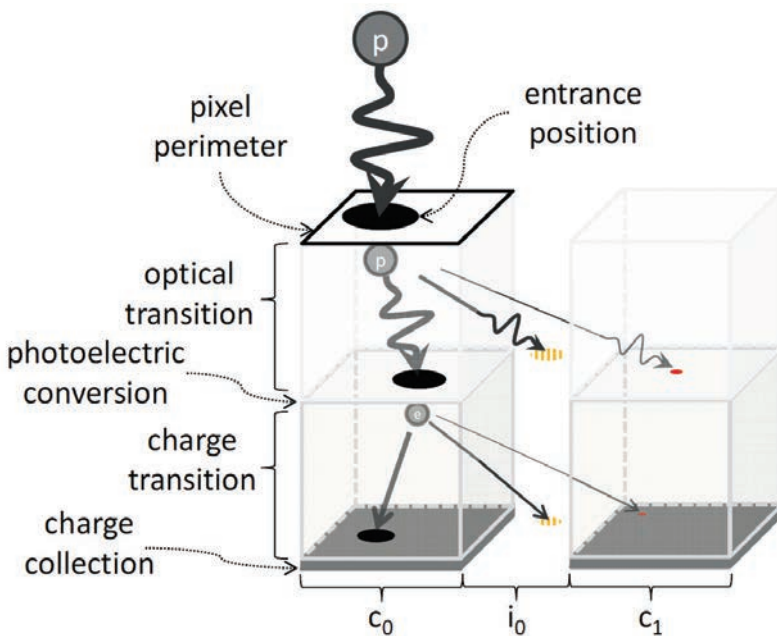

Figure 10 Examples of imperfect photon and charge collection contributing to IC, as well as the intended charge collection in c_0 (down-left). Two sensor pixels c_0 and c_1 with (exaggerated) intermediate area i_0 potentially housing circuitry such as anti-blooming functionality are illustrated. The vertical positions of the photoelectric conversion is not fixed or known a priori but are photon-individual, spectrally dependent and have a cumulative distribution functions with increasing probability of conversion through the optical transition.

9.4.1 Contribution

The significance of the review paper is the motivation of the potential for SNR and MTF improvements by reducing the generally overlooked image sensor imperfection of interpixel correlation (IC) that in the case of a color filter array (CFA) sensor, a very

9 • Summary of Original Work

common type of sensor, also causes color crosstalk. The work identifies research needed that would facilitate the characterization and reduction of the IC and consequently also achieve the potential SNR, MTF and color fidelity improvements.

In the context of IC reduction, the following notes may be considered as contributions, where notes 1-11 all are arguments for the significance of this neglected IC problem:

1. Avoiding sensor crosstalk and hence IC entirely is normally not possible or at least not desirable, as pixel crosstalk minimization normally comes at a cost (e.g. reduced sensor well capacity, read-out performance etc.), and will cause negative side-effects of dependent sensor other characteristics. This problem is further of increasing relevance for commercial image sensors like mobile phone cameras etc., due to the market pull for a minimization of sensor physical dimensions and also an increasing number of pixels, both, independently, contributing a reduced pixel pitch that tend to increasing crosstalk and blooming, hence increased IC and decreasing well capacity and MTF.
2. Even though a more profound analysis of the consequences of imaging having a (smaller) ratio of saturated pixels would be relevant for many applications of imaging in general, few reports fall outside all the following three saturated image strategies: a) “a saturated pixel is considered equivalent to a saturated sensor and hence an invalid sensor output to be discarded in its entirety”, generally overestimating the saturation effect b) “a saturated pixel is considered equivalent to one invalid pixel value to be discarded; the rest of the sensor output is considered unaffected and hence correct”, generally underestimating the saturation effect c) the topic of saturated pixels is not treated at all, although relevant for the application and at the best one of the approaches a) or b) is applied although not explicitly described.
3. The tendency of sensor crosstalk increasing with charge collected causes a conventional PSF characterization to be merely an approximation of a suggested more accurate irradiance-exposure dependent (IED) PSF, already for levels below saturation and deviation dependent on the energy accumulated in the sensor.
4. HDRI algorithms may be described by a common and general weight function strategy: ideally LDR pixel values of high SNR have a strong influence on the HDR reconstruction and LDR pixel values of low SNR have a weak influence, a strategy that may be named LDR SNR optimization. In often cited and highly influential HDRI algorithms, the weight function criteria are based on per-pixel impinging radiant energy to achieve the described LDR SNR optimization. The weight functions hence operate on an individual per-pixel basis. However, imaging systems have limited capacity of handling high radiant energy and limited MTF. Therefore an input of a certain high level of contrast shows IC inevitably affecting the surrounding and lowering the SNR of all pixels influenced by the IC.
5. The described radiant energy and MTF limitations are general sensing and imaging problems as such, but HDR scenes have per definition a potential of

9.4 • *Sensor Interpixel Correlation Analysis and Reduction: a Review (Paper IV)*

yielding a higher irradiance variation and higher contrast, thus potentially more severe IC problems.

6. The HDRI algorithms deliberately operating the sensor in also saturation, adding to IC and further motivates for the analysis and reduction of the IC effect.
7. If the described per-pixel weight function HDRI algorithm approach is modified to consider also the neighborhood or if the low SNR pixels could otherwise be avoided in the HDR reconstructing, the result SNR would improve.
8. Ignoring saturated pixel values (clipped hence underestimated pixel value) do not, as claimed in the literature, cause blooming artifacts to have little impact per se, the level of impact is dependent of the level of contrast of the scene imaged in relation to the level of blooming resilience of the sensor. If the sensor blooming resilience does not match or surpasses the demands set by the imaging task e.g. in a scene causing high irradiance and high contrast, the weighting function may give high influence to blooming affected (charge receiving pixels, hence overestimated pixel values) mid-tones deteriorating the reconstructed radiance values, even if saturated pixel values are ignored. Blooming increases IC.
9. The “brighter fatter effect” (widening of PSF with charge accumulation) is likely of especial relevance for HDRI where the sensor is deliberately operated in also saturation, as the widening of PSF (a close-neighbor-correlation transforms into a further-away-neighbor-correlation) show a strong increase, for impinging radiant energy close to sensor saturation. There is no reason to expect that the effect of widening of PSF at (and above) saturation will be less than the worst case reported when operating the sensor in the range from significantly below saturation, to nearly saturation.
10. Imaging under saturation inevitably introduces a compound PSF behavior and at high enough exposures blooming that further results a rapid increase in lateral spreading. Optical scattering and reflections at the surface (circuitry) layers of the sensor will, at high irradiances, add to the PSF compound behavior. Under these HDRI representative conditions, where principally different physical processes contribute to a compound PSF, deconvolution using conventional linear PSF is likely not effective in removing the IC, i.e. using established deconvolution methods. More sophisticated decorrelation methods are required.
11. The IC caused deficiency of output from physical, non-ideal, image sensors impose specific analysis challenges, especially true for HDRI as the analysis generally is a) an inverse, b) an ill-posed, c) an ill-conditioned and d) non-linear problem. The arguments a)-d) may together indicate likely reasons why the since long identified potential of LDR image noise reduction, implying a higher SNR HDR reconstruction, have not yet resulted in effective IC reduction algorithms or at least focused efforts and studies.
12. The IC deficiency analysis challenges give arguments for an introduction of problem relaxation or other nonconventional approach to better analyze and mitigate IC in the LDR even if the solution may be sub-optimal. At least as an

9 • Summary of Original Work

intermediate achievement, striving for the ultimate goal of calibration to achieve uncorrelated pixels (zero IC).

13. Arguing that the IC is both neglected and important may appear surprising as negative effects are not widely reported in the literature but four reasons given may explain and motivate, the four are the weight function design, context-filtering, a noise masking effect, and saturation ad-hoc size exclusion which are all merely work-arounds or an inability to detect. Therefore, these four reasons are arguments for potential improvements if the source IC can be reduced.

9.5 Sensor Interpixel Correlation Analysis and Reduction for Color Filter Array High Dynamic Range Image Reconstruction (Paper V)

High dynamic range imaging (HDRI) is demanding as it deliberately is operating the image sensor in saturation, causing increasing crosstalk and possibly blooming and smear, lowering the Modulation Transfer Function (MTF). Well-established HDRI algorithms exclude saturated pixels but generally overlook these interpixel correlations (ICs), possibly due to the intricate analysis required.

In this paper, a calibration method developed estimated the affected proximity region of saturated pixels for a color filter array (CFA) sensor by evaluating and minimizing the resulting color crosstalk given a set of hypothesis proximity regions, without the need of specialized measurement equipment. The introduced metric is based on singular value decomposition of the observed sensor data and the analysis of the residue after zeroing the first (maximum) eigenvalue of the sensor data. This facilitates the analysis and minimization of interpixel correlation as a function of proximity region eliminated.

The result is illustrated for a demanding HDR test target generating a 22-bit dynamic range of improved high color-fidelity and decreased noise. The calibration is performed only once for a given sensor, thereby reducing IC in the low dynamic range images. The calibration improvement is applicable to any HDRI algorithm based on CFA image bracketing, irrespective of sensor technology. Generalizations of the calibration method presented operating on saturated pixels only and ignoring the level of saturation, to an operation on all pixel levels in the range from non-saturated levels to sensor super-saturation, were described.

9.5.1 Contribution

Novel aspects of the paper include:

1. The method implemented facilitating the detection, analysis and reduction of the IC affected surrounding of saturated pixels in the LDR CFA sensor images, improving the LDR SNR thus the HDR reconstruction.
2. The method using sensor intrinsic CCD Bayer mosaic CFA as a matched filter for IC detection (confer the LIGO gravitational-wave detection system, facilitated by the interferometer principle of a matched filter taking the difference of

9.5 • *Sensor Interpixel Correlation Analysis and Reduction for Color Filter Array High Dynamic Range Image Reconstruction (Paper V)*

anti-correlated (extraction/contraction) terms. All contributing to an utterly sensitive detection system).

3. The introduced metric for the estimation of IC contamination, based on well-established singular value decomposition analysis, as the tool for IC contamination minimization.
4. A detailed generalization to estimate and reduce as well sub-saturation as super-saturation IC is described.
5. A generalization to an irradiance-exposure dependent (IED) PSF, covering also super-saturation levels is described.
6. The described potential IED PSF characterization, utilizing established HDRI methodology: the set of exposure bracketed LDR images, imply each position being multiple-sampled at different exposure-compensated sampling characteristics which may be described as an over-determined equation system, albeit with noise and IC.
7. A “charge repatriation strategy” (CRS) is described, based on the IED PSF that may further mitigate IC for every level of radiant energy of the LDR images for HDR reconstruction.
8. The alternative characterization method describe based on CFA matched irradiation sources enhancing the characterization potential (albeit less illustrative and less pedagogical, compared to the method presented in detail in the paper).
9. The introduced method may algorithmically be described as a pre-processor separated from the HDRI algorithm, to mitigate the IC in the LDR images. Hence, other CFA HDR reconstruction algorithms that do not consider IC, or do the reduction less effectively than the presented method, may adopt the method as a separate pre-processor without a need to otherwise modify the HDR algorithm thus increasing the SNR of the result HDR reconstruction, irrespective of the HDR reconstruction algorithm used.
10. The presented algorithm is inspired by a general imaging processing heuristic of mitigating distortion at the source. In this case, the IC of as well sub-saturation as super-saturation operation of image sensors resulting a systematic output error. This differentiates the present algorithm from the workaround strategy of established HDRI algorithms, neglecting the IC and instead only implicitly reducing the IC consequences in general imaging SNR enhancing operations. Implicit reduction of IC is less effective and tends to introduce undesired side-effects (artifacts).
11. The presented algorithm is applicable and relevant for as well a wider range of HDRI applications (including both exposure fusion and radiant power calibrated applications), non-HDRI applications e.g. circuit-integrated (native) signal processing in Wide Dynamic Range-sensors as imaging in general, as sensor IC resilience is always an optimization with competing characteristics. Hence every physical sensor raw output is deteriorated by a non-zero IC and a potential for improvement.

9 • Summary of Original Work

12. The presented algorithm may be more favorable in the mitigation of the PSF widening (brighter-fatter effect), than established described and referred to algorithms as the presented approach does also calibrate and undo saturated sensor side effects, hence potentially opening a wider irradiance energy regime of sensor operation.

9.6 Spatially and Angularly Resolved High Dynamic Range Reflectance Measurements for Forensic Document Inspection (Paper VI)

Detailed optical characterization of the perceptually relevant features of optically variable devices (OVD), a concept of the optical document security business, is in general a challenge. Adding to the generally high spatial resolved characteristics and angular resolved characteristics, the high dynamic range of reflection, including high intensity specular reflections and low intensity reflections of other geometries make the metrology even more demanding.

The paper introduced a realized trichromatic reflectance measurement system that met the stated challenges. The resulting data may be described as a spatially resolved trichromatic goniophotometric characterization. The massive data set generated may be approached either by developed visualization tools (static images and dynamic videos) or as suggested processed mathematically into higher-order characterizations such as simulations of human visual perception via spatial filtration.

Relevant applications include a detailed angular characterization of the iridescent color shifts; how the iridescence function is distorted due to the topography of the underlying paper. The application is demanding in part because the analysis involves spatial and angular dimensions over a high dynamic range of reflectance (specular and non-specular). The potential other relevant applications are abundant but the realization should be guided by the end-use specific needs.

9.6.1 Contribution

Novel aspects of the paper include:

1. The OVD measurement and characterization principles introduced and realized, adopting the beneficial illumination-sample-sensor configuration, inter-sampling incremental rotations and Cartesian metric transformation described in previously published gloss measurement principle (**Paper II**), resulting a similar angularly and spatially resolved information set, however generalized to also color characterization.
2. The IC reduction (**Paper V**) applied, hence providing exceptionally HDR capabilities including low noise levels, illustrated in Figure 6.
3. The significant resemblance of the measurement principle and characterized information, with the information gained by first line inspection (human visual perception based evaluation) of OVD, as performed by experienced judges,

9.6 • Spatially and Angularly Resolved High Dynamic Range Reflectance Measurements for Forensic Document Inspection (Paper VI)

thereby potentially measuring first line inspection significant aspects influencing the verdict of an experienced judge.

4. The introduced Reflectance Volume (RV), being a 3D trichromatic reflectance, spatially and angularly, high-resolved and calibrated information set is accurate first line influential characteristics of OVDs.
5. The RV facilitates visualization and other further processing.
6. The introduced two orthogonal plane information-selection from the RV as an effective means to visualize characteristic features in a static medium, such as a thesis.
7. The generality of the RV characterized are indicated by three principally different OVD case studies:
 - a) local angular deviation in appearance due to inaccurate production (non-circulated banknotes) visualized and characterized with sub-degree resolution;
 - b) the optical function degeneration due to circulation visualized and characterized as the degeneration of the optical characteristics, as a function of the apparent degree of wear;
 - c) detectability of OVD features and the influence of e.g. contrast, feature size and viewing distance, visualized by operating the Modulation Transfer Function (MTF) of the Human Visual System (HVS) on the RV.
8. The explanatory potential of the RV characterized is indicated by investigation conclusions for the three principally different case studies, including:
 - a) the local angular deviation in appearance is for the sample illustrated likely due to paper topography variation rather than inaccurate OVD, based on the congruent gloss PA direction deviation of the same local coordinates;
 - b) the optical function degeneration due to circulation is illustrated and quantified (angularly, spatially chromatically) – conclusions include a) the increase of chromatic haziness of chromatic features (irrespective of local inclination) and b) the increase of paper topography variation, both as a function of the degree of wear;
 - c) detectability, the band-pass (contrast enhancement) character of the MTF of the HVS is amply illustrated, of importance e.g. when designing the OVD graphic lay-out to effectively facilitating first line (human) detection and when estimating the MTF caused diffusion of the shattered colors of the heavily circulated banknote at a desired viewing distance range of say 250 - 350 mm.
9. A described potential application estimating the likelihood that two characterized and analyzed OVDs are produced by the same originating equipment. This characterization is facilitated by the capabilities of the RV and is of high relevance when presenting facts in court [54], e.g. arguing that a counterfeit banknote, passport document or item OVDs found in circulation originates from a certain counterfeit production site.

9.7 Forensic DOVID reader, bridging 1st, 2nd and 3rd line inspection (Paper VII)

First, second and third line inspections are cornerstones in the optical document security industry. Individually these three inspection modes provide crucial functionality contributing to the counterfeit deterrence of optically variable devices (ODS), but they suffer the inability to act as a well-integrated inspection system. Negative consequences include inferior functionality design, as the potential counterfeit deterrence benefits if holistic and well-integrated system functionality design of the three inspection modes would instead be adopted. Other negative aspects include the inability to give objective, substantially informative and indisputable characteristics of the first line security features.

This paper introduces characterization methods based on the previous measurement system and the resulting RV. The methods provide the potential of estimating differences between the features as appreciated by perceptual evaluation. Advantages include a) facilitation of performance evaluation of different DOVID (or other similar types of OVDs) suppliers possibly estimating the adherence to product specifications (Program of Requirements) as detailed in procurement documents, future defined standard or similar documentations; b) gaining more detailed understanding of the optical deterioration due to circulation; and c) the forensic evaluation of different groups of counterfeits potentially originating from the same production equipment.

The introduced and implemented higher-order characterizations focus on angular and spatial iridescent color deviations. The deviation may consider the difference of two genuine and ideally identical DOVIDs or the influence of circulation, deteriorating the optical performance relative to an ideal non-circulated genuine DOVID. The characterizations introduced together with supporting visualizations motivate claims a) — c) above.

9.7.1 Contribution

Novel aspects of the paper include:

1. The generic methods implemented providing DOVID higher level optical descriptors of significance for the understanding of DOVID performance in a first line visual perception based inspection. Results include samples of DOVIDs of the Swedish 100 Kr and the €500 Alphagram[®] DOVIDs.
2. The evaluation method operating either on the entire DOVID, or on one or multiple spatial sub-areas identified autonomously by given feature based (i.e. not inferior coordinate-based) detection criteria at choice. Thereby characterizing the angular dependent trichromatic reflectance at a high method specificity and sensitivity as only the target information is considered (omitting the irrelevant surroundings).
3. The abilities and robustness of the evaluation methods being a consequence of:

9.7 • Forensic DOVID reader, bridging 1st, 2nd and 3rd line inspection (Paper VII)

- a. the measurement completeness, i.e. to consider the most influential aspects of OVDs with respect to a first line inspection;
 - b. the explanatory potential of characterization protocol to achieve the significant (non-redundant and orthogonal) RV;
 - c. the high repeatability of the measurement system;
 - d. the high signal-to-noise ratio of RV information.
4. The implemented method delivering calibrated results in image spatial coordinates [mm, mm], angular coordinate [degree] and in terms tri-chromatic reflectance (calibrated to spectrally defined radiance, if desired).
 5. Visualization methods that facilitate the identification, and angular and spatial characterization of physical optics based characteristics like -2th, -1th, 0th, 1th and 2th diffractions, describing features that are also established in the ODS industry.
 6. The range of activities significantly facilitated by the introduced methods detailed and motivated in the paper includes quality assurance, product development, standardization and forensic analysis. More specifically, the introduced methods opens for new relevant applications:
 - a) security document standards based on characteristics relevant for first line inspection;
 - b) evaluation environment standards based on characteristics relevant for first line inspection;
 - c) security document design strategies to achieve a robust security document system having a graceful performance degradation under e.g.:
 - i) document circulation, tear and ware (hence suboptimal document optical performance relative to the ideal fresh (non-circulated) document);
 - ii) suboptimal evaluation environment (e.g. evaluation under dim light) and
 - iii) suboptimal HVS i.e. a visually impaired due e.g. to color blindness or suboptimal HVS MTF due e.g. to myopia (near-sightedness), hyperopia (far-sightedness) or macular degeneration.

9.8 Information Capacity Revisited - Reflections on Print Quality (Paper VIII)

Instrumental based print quality measurements aim at objective estimates of visual perception based print quality evaluation results as conducted by a panel of judges. In this paper the measurements proposed in the literature are discussed and related to perceptual evaluations.

Already several years before the paper was published, the concept of information capacity was proposed as such a measurement, inspired by the successful application in e.g. telecommunication. But the interest of information capacity based print quality applications has never been large. Questions like: “Why have we seen so few applications of this theory for practical applications in the area of print?” and “Is the area of print quality so very different from the areas of image compression and telecommunication?” may be raised and are treated in this work.

9.8.1 Contribution

The work is focused on the potential of an information theory based print quality related characterization, a forward-looking work which scientific relevance may be questioned. However, put into the context of the chronologically later work (**Paper IV - Paper VII**) with the RV characterization, and with trivial generalizations of this paper (**Paper VIII**), the work reforms to be of relevance, strengthening arguments for applications like standardizations and product characterization protocols, of high importance for the security document industry.

The RV is exceptional in the combination of measuring a) a number of different dimensions of significance in a first line (human evaluator) inspection of OVDs and b) the high dynamic range of reflectance at the high SNR and spatial and angular resolutions resembling the resolutions for a human evaluator. The combination result in an information-set characterized by both having large entropy and being significant for first line inspection.

This opens for principally new and potentially influential applications of information theoretic based security document performance characterizations. Obvious application characteristics include detectable information content influenced by motif spatial dimensions [mm], spatial resolution [resolvable coordinates/mm], radiometrically resolvable levels (“number of colors detectable by a human judge”) and angularly resolvable levels. These orthogonal dimensions are influenced by a) the product characteristic (the product potential available information content), b) the evaluation environment specifications (dealing e.g. the spectral distribution and power of radiance of radiator or, less specifically, color temperature and intensity of the illuminator etc.) and c) the human judge (HVS MTF, color vision acuity, ability to evaluate OVDs etc.). With the necessary “instrument” characteristics of a)-c) it is possible to estimate the potential channel capacity of this security document system.

As these indicated future applications are not described in the paper but identified later, this section may rightfully be described as speculative, however not without a potential.

9.8.2 Thesis author’s contribution

The work is co-authored by Prof. Björn Kruse then my supervisor, acting as the sounding board especially regarding the ideas and framing of the paper. The thesis author was the main contributor to the paper.

9.9 System integration — intersectional challenges and achievements

Sections 9.1 to 9.4 and 9.6 to 9.8 relate to peer-reviewed papers, and each of Sections 9.1 to 9.8 describing vital part-functionality of the measurement, characterization and visualization system. In this section, remaining vital functions, knowledge or other aspects necessary for the development of the integrated and fully functioning system, will be briefly described:

9.9 • System integration — intersectional challenges and achievements

1. The multidisciplinary character of human perception relevant measurement, characterization and visualization applications for gloss and OVD products require significant knowledge in the fields of:
 - a) visual perception based evaluation, including aspects of perception psychology and human vision system;
 - b) protocol design, including necessary and sufficient information concepts to describe visual gloss and OVD characteristics, and design of manipulation operations to a better understanding, facilitating a searched for solution;
 - c) electro-mechano-optics necessary for the development of the measurement rig, including mechanical construction, optical system design and construction, and the (low level) software application interfaces;
 - d) information representation design, including necessary and sufficient dynamic ranges (spatial extension, angular range, radiant power envelop), and resolutions for these dimensions;
 - e) data sampling, including the physical realization of the data collection in accordance with the protocols and information representations;
 - f) characterization, including data retransformation to information in accordance with the protocol and information representation;
 - g) visualization interface design, including interaction design to facilitate presence and suspension of disbelief;
 - h) visualization interface implementation, including software architectural design to achieve necessary high visual fidelity and short response time to achieve the design criteria.

The first version measurement rig was designed and constructed during the author's master's thesis work [11].

2. Software design and implementation. All software, except a camera sensor application protocol interface transferring the raw (unprocessed) data from the sensor to the computer frame grabber interface, has been designed and implemented within the project by the author, including:
 - a) control procedures for the autonomous spatial calibration of sample holder positioning relative to the illumination and camera;
 - b) control and monitoring procedures for the illumination power supply;
 - c) control and monitoring procedures for client-server file transportation, necessary due to the data volumes generated in already one (autonomous) measurement session in relation to the data capacity of the measurement computer;
 - d) parallel computing (multi-processor distributed computing) based data processing of the measurement session massive output to intermediate information representation including process-oriented programming concepts to handle and resolve concurrency by introduced so-called semaphores. The motivation for such highly specialized software engineering concepts was to retain the software based flexible measurement principle while achieving substantial time performance improvements. If instead the measurement principle would have been fixated, the data retransformation would have been made many orders of magnitude more efficient in terms of data operation (i.e. time performance) and data storage, which is beneficial especially

9 • *Summary of Original Work*

in a finalized version of the measurement system. However, during research and development, the flexibility of the architecture of the software platform is prioritized and alternative measures to achieve a reasonable processing performance and response time for results are more favorable.

9.9.1 Thesis author's contribution

The electro-mechano parts of the measurement rig was developed by the thesis author in cooperation with Jarmo Tulonen, a skillful and highly professional sounding board during the design and construction of the measurement rig, i.e. sample rotation function, imaging holder and illumination holder sub-systems. Jarmo's knowledge regarding especially transmission systems for electro-mechano-optics facilitated a sample positioning with the necessary accuracy, including an exceptionally low rotational hysteresis. His expertise regarding the coordination of the fabrication of the measurement rig is also noted.

The optics, i.e. lens systems for the imaging and illumination devices and the design and construction of the illumination system was developed by the thesis author in cooperation with Christer Alvfors at Tekno Optik AB Stockholm. Christer's knowledge in integrated electro-mechano optical system and his willingness to discuss the multiple aspect design problems was influential for the result optical performance.

The other activities, mainly focused on software design and implementation (Matlab[®]) was performed by the thesis author.

10

COMPARISON OF THE INTRODUCED SYSTEM AND UNIVERSAL HOLOGRAM SCANNER

The system developed and introduced in this thesis is commercially available via gonioLabs AB. Other commercially available instruments that characterize the perceptually significant optical behavior of OVDs are missing. However, a relevant instrument to relate to is the Universal Hologram Scanner (UHS), developed by Steve McGrew of New Light Industries (USA), announced in 1998 and since 2000 in use for forensic investigations at the Counterfeiting Intelligence Bureau (ICC).

This chapter relates to Chapter 9, both aiming to give credibility to the previous claims of applicability. However, while the former chapter references are authored or co-authored by the thesis author, this chapter is citing a third party authority, motivating the separate chapter.

The renown and distinguished late authority Rudolph (Ruud) van Renesse has reviewed and outlaid the potential of both the UHS [55] and the introduced system in **Work ix**. The thesis author has briefly referred to van Renesse's comparison of the two systems (**Paper VII**, section 5⁴ "DISCUSSION").

In a private communication in April 2008, van Renesse, details his view on the differences between these systems (the text is an excerpt from an e-mail communication with van Renesse):

The two currently available general purpose DOVID analyzing systems are: gonioLabs' DOVID reader (GDR) and New Light Industries' (USA) Universal Hologram Scanner (UHS).

While the GDR is capable of sampling the optical characteristics of a diversity of surfaces, whether diffusely scattering or diffractive (but not thin film interference effects), the UHS is dedicated to characterize DOVIDs only.

⁴ Intentionally no hyperlink.

10 • Comparison of the Introduced System and Universal Hologram Scanner

The UHS measures the diffractive behavior of either selected diffractive elements or the integrated diffraction of many or all diffractive elements of a DOVID in the Fourier (frequency) plane. As a result, the UHS renders a 2-D “fingerprint” of a DOVID, including the response of virtually all fringe orientations present in the DOVID. Interestingly, the UHS also reveals covert laser read (CLR) images of both the Fourier and the Kinoform type.

Contrary, the GDR displays the characteristics of diffractive elements having fringe patterns orientations virtually in one direction and the DOVID must be mounted with different orientations to reveal the characteristics of diffractive elements with different fringe orientations. The GDR does not reveal CLR images. An advantage of the GDR is that it samples a complete set of angular responses of all spatial locations of a DOVID, thus allowing for statistical analysis, modelling and signal processing.

Apparently both systems have their pros and cons and they might well serve to render complementary forensic services.

11

SUGGESTED FUTURE WORK

The methods presented can, inspired by the general body of knowledge, be generalized in a multitude of different ways of relevance for certain optical document security applications and the specific needs associated. Some of these generalizations may be straightforward to implement, straightforward at least having a moderate level of characterization ambition (going deep into details – also seemingly simple questions tend to become intriguing). Examples of straightforward generalizations include an introduction of polarization filters in the optical path. The characterization of polarization effects may appear contradicting the argumentation in Section 5.1 to neglect features not detectable by the human visual system but can still be relevant for optical document security niche applications using polarization filter optical aid for first line inspection. Other straightforward generalizations may include multiple-source illuminations representing different positions, beam-characteristics, spectral composition etc. operated ideally solitarily sequentially or jointly, to characterize more aspects of the document.

Two less obvious generalizations that also relate closely to first line inspection are: generalization of one-plane (1D) of inclination, and generalization to photoluminescence materials. The former refines the methods to more exhaustively handle a 2D OVD, having a two-dimensional inclination dependent appearance. The latter generally requires a demanding characterization procedure, but may be motivated for, intentionally or unintentionally, spectral-response intriguing security documents. Such characterization facilitates the understanding and simulation of first line inspection performance in a range of different inspection environments having sources of different spectral radiation. This type of simulations may reveal a significant difference in appearance, especially if the document contains photoluminescence materials. Such deeper understanding is of importance during an OVD integration process when the OVD should work in concert with surrounding other substrates without appearance and inspection disharmonies; when specifying Program of Requirements for an OVD procurement process; and when formulating standards for optical document security components. These two generalizations will be described in more detail in the following.

11.1 Generalization of one-plane of inclination

One aspect of human visual perception based evaluation of angular dependent appearance neither described in Chapter 3 nor so far covered in the measurement, characterization and visualization methods in this thesis is the human binocular vision, i.e. two cooperating eyes and vision channels, facilitating stereopsis. Stereopsis is most often referring to the ability to depth of view and the mental process in the visual cortex of gaining knowledge of the (macroscopic) 3D environment. Stereopsis requires an eye disparity (distance between the eyes) causing nuance, albeit significant, difference in the visual stimulus in the left and right eye. In a more general sense stereopsis may be described as enhanced level of information gained, facilitated by the visual cortex processing of the eye disparity stimulus. Such revised formulation includes also the sensation of products such as so-called volume holograms and 2D OVD features. These cause left and right eye to obtain intentionally different stimulus, caused by the carefully realized microstructure, and the optical refraction to simulate a macroscopic 3D structure. In contrast: everyday product having a physical macroscopic 3D structure in the environment that causes the related depth of view.

These optically sophisticated 2D OVD features giving different sensations in the left and right eyes, causes the binocular vision to convey more information than do a monocular inspection. Moreover, a 2D OVD is generally more complex than a human binocular based inspection, changing the inclination of the document in only one angular dimension is able to capture. The left and right eye sampling do, despite the information carrying difference of the binocular vision, hence generally not resolve the relevant degrees of freedom for these types of sophisticated products. To fully perceive and characterize such products, the inspection must, in a general case, be performed in every possible 2D resolved inclination, i.e. an exhaustive search in the 2D inclination space.

The measurement, characterization and visualization methods in the thesis are designed to meet all the significant needs related to 1D OVDs. The methods approximate the optical behavior of 2D OVDs as would an inspector shutting one eye. A generalization may take either of two approaches, depending on the level of ambition. At a moderate level of ambition, case a), the methods mimic and relate to the stereoscopic ability of the human visual system. In a more ambitious generalization, case b), the methods approximate 2D OVD exhaustive measurements, characterizations and visualization, however under a certain specified assumption. These two generalizations cases a) and b) are referred to and described in the following Subsections 11.1.1 to 11.1.3.

11.1.1 Generalizing the measurement

To generalize the measurement method to mimic a stereoscopic perceptual evaluation, i.e. case a) above, either the monocular camera is complemented with a binocularly disparate second camera, resulting a binocular measurement, or the OVD holder is equipped with a two-stage tilting function, orthogonal to the plane of inclination, that is changed during the measurement. Thus, two consecutive measurements will, with an intermediate change of the two-stage tilt, collectively hold the information of a

11.1 • Generalization of one-plane of inclination

binocular measurement. Comment: there is a principal difference between these two generalizations in the relative configuration of the illumination-substrate-camera, however so small that it falls outside the scope of this presentation.

The more ambitious generalization, case b), is in general difficult but insightful problem relaxations may alleviate the demand for an exhaustive 2D angle measurement without sacrificing significant explanatory power of the result. Performing two consecutive measurements with an intermediate 90° rotation of the OVD will collectively hold information of an orthogonally dual 1D measurement, i.e. two angularly fully resolved measurements in the two orthogonal inclination dimensions. These measurements are obviously far from an exhaustive 2D inclination measurement procedure that would capture every optical behavior within the 2D angle-space measured, including possible transient and non-regular responses as a function of the 2D angle variable. However, based on the experience of a large number of principally different 2D OVDs and more importantly the knowledge about the physical laws involved in the published technologies to achieve the optical characteristics, it may be assumed that the optical response do generally not show transient or non-regular responses as a function of the 2D angle variable. These assumption are applicable e.g. for the frequently used approach of diffractive elements having fringe patterns with different fringe orientations. In fact, a hypothesis construction of such described transient response interleaved in an otherwise ‘ordinary’ regular response 2D OVD is most likely inherently difficult. Therefor the assumption of a regular optical behavior, without transients, may not be a severe limitation and the described two orthogonal inclination measurements will likely capture the visually significant optical behavior of a majority of realized 2D OVDs.

In fact, in the previous Licentiate thesis project (**Work iii**) [10], this approach was tested, however only for a graphic paper gloss product. This was done adopting the b) generalization, i.e. by performing two measurements of the same physical surface, the sample being rotated 90 degrees around the axis normal to the surface for the second measurement. The two measurements are then merged. Challenges arise however concerning the matching, both in terms of rotation (around the axis normal to the surface) and in terms of spatial translation. With a spatial resolution of 20 μm (as it was then using other optics and a monochrome sensor), the matching could not be done by hand solely, but was aligned to sub-pixel resolution by implemented rotational and translational software based corrections in order to achieve the necessary resolution and precision.

11.1.2 Generalizing the characterization

The measurement generalizations described, irrespective of ambition a) or b), cause no imminent need to modify the described reflectance volume (RV) protocol, albeit with a higher data dimensionality of each volume element (voxel). The characterization procedure may hence be retained.

However characterizing the measured full data into a more compact approximate representation alleviates data storage needs, may improve data interaction speed performance facilitating e.g. a lag-free interactive visualization etc. Such characterization may in a most straightforward approach be a 2D inclined facet and an intensity or

11 • Suggested Future Work

RGB-triplet, a representation without the ability to capture iridescence effects acceptable e.g. for graphic paper products but not for OVDs.

A more sophisticated angle dependent parameterized representation may model the diffraction caused iridescence effects. One hypothesis model may approximate the local fringe pattern orientation based on the two orthogonal inclination measurement, i.e. based on the alternative b) above. By assuming the diffraction is caused by a locally regular (not-changing within the pixel) pattern, the rate of iridescence color change as a function of the two orthogonal inclinations are interdependent (of the inclinations) which facilitates the calculations for the estimate (pixel) local fringe pattern orientation. Depending on the level of OVD optical sophistication, such an approximation may or may not capture the actual OVD optical behavior. To quantify this deviation in optical response requires however an exhaustive 2D inclination measurement.

Focusing only on the deviation from a RV and a more data compact representation, a residue (error) controlled sampling may be desirable. The deviation of the approximate representation from the RV may thereby be controlled and e.g. limited by an arbitrarily chosen and specified residue upper bound, at the cost of the resulting (i.e. not known on beforehand) data volume necessary to achieve the specified fidelity.

In the Licentiate test-implementation (**Work iii**) [10] for graphic paper gloss products, a complex (real and imaginary integrated) data type was used for the inclination representation. The complex data type representation was chosen in part as it is an efficient and convenient information representation. However, the short response time for (software language native) complex arithmetic, compared to composed alternatives, was the main reason. This was crucially important, i.e. to avoid a resulting visualization interface lag, that would otherwise significantly deteriorate as well the user-experience, the degree of presence as the suspension of disbelief.

11.1.3 Generalizing the visualization

The generalizations thus far described cause need for changes in the visualization interfaces. The non-interactive visualization, Section 7.1, may adopt a binocular interface such as active-shutter glasses to mediate moderate ambitious 2D inclination visualization. However to generalize the non-interactive visualization to an exhaustive 2D inclination visualization another approach than what is described in Section 7.1 needs to be developed and is beyond the scope of this thesis.

For the interactive visualization, Section 7.2, no imminent need to modify the described visualization protocol, as the visualization interface already has a 2D inclination freedom. In the Licentiate thesis (**Work iii**) [10], the approach b) described in Section 11.1, was tested (a mock-up or “skunk work”) for as well measurement and characterization. Thanks to the complex representation, the 2D inclination visualization was only marginally slower than the original 1D inclination and significantly faster than an intuitive (straightforward) implementation, generalizing the 1D to 2D inclination visualization.

A simulation based on such a full 2D-facet inclination RVM is shown in Figure 11. The sample was a “Light Weight Coated” paper printed in a heat-set offset printing

11.1 • Generalization of one-plane of inclination

press, a product sensitive to improper production conditions. The virtual sample holder in the visualization tool is set to equal curvatures in the x and y directions, see Figure 11. Note here the enhanced level of inspection freedom of the virtual inspection studying a surface under a 2D curvature configuration, which is not possible for a physical paper surface, as it would become buckled. (If desirable, restrictions on the virtual sample holder shape corresponding those of physical documents are of course possible and trivial to introduce and implement.)

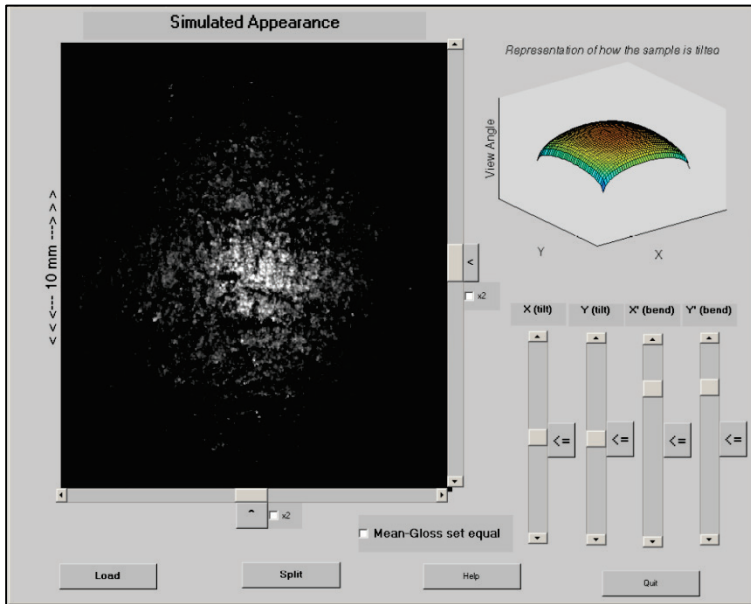

Figure 11 2-D angle resolved interactive visualization, from Work iii.

In principal, the interactive visualization interface is able to mediate all the relevant information of a 2D OVD and represented in the described generalized RV, albeit only for one monocular channel at the time. However rendering the simulated response by accessing the RV information directly, without a performance enhancing middle-ware representation, the response time would be overwhelmingly slow. Therefore a complement representation, as indicated in Subsection 11.1.2 is necessary and influence also the rendering algorithm of the visualization interface. This have not been implemented or tested. On the other hand, for specific application e.g. when considering hypothesis product specifications, also very slow simulation of optical behavior may meet the critical needs and the implementation as-is may be sufficiently capable.

To mediate also a binocular inspection 2D OVD behavior, as perceived in ordinary inspection, a generalization of the visualization interface to e.g. active shutter stereo display glasses is needed. This generalization should be trivial.

11.2 Generalizing to photoluminescence materials

The description, in Chapter 3, of light reflection from documents may be generalized. By measuring the “light” interaction with the document as a function of the source radiant power spectral distribution and characterizing the result wavelengths energy redistribution, more relevant information may be gained. To achieve this, the wide-spectrum illumination may be exchanged for a narrow-band irradiator and the Bayer CFA sensor may be exchanged for narrow-band resolved imager system, e.g. using filter revolver system and performing a sequence of incremental characterization to achieve the (two-dimensional) full-spectra characterization. With this approach also photoluminescence materials may be characterized adequately. Such material transforms electromagnetic radiation wavelengths either near-synchronously (fluorescence) or with a temporal delay of up to hours (phosphorescence).

This type of so-called radiance factor (Donaldson) matrix characterization [56] is able to describe optical “whitening” agents, frequently used e.g. in office paper, transforming invisible (outside the detectable spectrum of the HVS) electromagnetic radiation to visible ditto (“light”) with the purpose to make the product appear brighter. Having characterized the radiance factor matrix it is possible to estimate the response and appearance of a photoluminescence products under illuminations having different spectral distributions. This is especially important during product development, defining necessary optical performance requirements so that the product will meet the expectations in also sub-optimal specified inspection conditions and for defined visually impaired observers.

A radiance factor matrix, optionally also with a temporal characterization, in combination with the methods described in this thesis further opens for novel optical document security features that may be very challenging to characterize without a described sophisticated characterization abilities, therefore also challenging to simulate. If properly architected and realized, such features may have a both conspicuous and predictable (robust) appearance when excited by also technically trivial and inexpensive temporarily controlled illumination sources. Such feature characteristics are highly desirable in a first level inspection verification system.

Bibliography

- [1] R. L. van Renesse, *Optical Document Security* 3 ed., Artech House, Norwood, MA, 2005.
- [2] M. Lindstrand, Instrumental Gloss Characterization - In the Light of Visual Evaluation: A Review, *J. Imaging Sci. Techn.* **49**(1): 61-70 (2005).
- [3] M. Lindstrand, An Angularly and Spatially Resolved Reflectometer for a Perceptually Adequate Characterization of Gloss, *J. Imaging Sci. Techn.* **49**(1): 71-84 (2005).
- [4] M. Lindstrand, An Interactive Gloss Visualization Environment - For Measured or Simulated Surface Data, *J. Imaging Sci. Techn.* **47**(4): 346-356 (2003).
- [5] M. Lindstrand, Sensor Interpixel Correlation Analysis and Reduction: a Review, *J. Imaging Sci. Techn.* **63**(1) (to be published in 2019).
- [6] M. Lindstrand, Sensor Interpixel Correlation Analysis and Reduction for Color Filter Array High Dynamic Range Image Reconstruction, submitted to *Color Res. Appl.*, (2018).
- [7] M. Lindstrand, Spatially and Angularly Resolved High Dynamic Range Reflectance Measurements for Forensic Document Inspection, *Optical Document Security - The Conference on Optical Security and Counterfeit Deterrence*, San Francisco, CA, USA, January 23-25, 2008, (Reconnaissance International).
- [8] M. Lindstrand, Forensic DOVID reader, bridging 1st, 2nd and 3rd line inspection, *Optical Document Security - The Conference on Optical Security and Counterfeit Deterrence*, San Francisco, CA, January 20-22, 2010, (Reconnaissance International).
- [9] M. Lindstrand and B. Kruse, Information Capacity Revisited - Reflections on Print Quality, *Advances in Printing Science and Technology*, Vol. 26, pp. 175-184, Munich, Germany, September 5-8, 1999, (Pira International), 2000.
- [10] M. Lindstrand, Gloss: measurement, characterization and visualization - in the light of visual evaluation, Licentiate thesis, Linköping University, 2002. <http://citeseerx.ist.psu.edu/viewdoc/download?doi=10.1.1.105.5287&rep=rep1&type=pdf>, accessed 30 August 2018.
- [11] M. Lindstrand, A conceptual approach to describe gloss variation in printing paper, Master thesis, Linköping University, 1996.

Bibliography

- [12] C. E. Shannon, A Mathematical Theory of Communication, *The Bell System Technical Journal* **27**(3): 379 - 423 (1948). <http://dx.doi.org/10.1002/j.1538-7305.1948.tb01338.x>.
- [13] C. E. Shannon, A Mathematical Theory of Communication, *The Bell System Technical Journal* **27**(4): 623 - 656 (1948). <http://dx.doi.org/10.1002/j.1538-7305.1948.tb00917.x>.
- [14] R. Sève, Problems Connected with the Concept of Gloss, *Color Res. Appl.* **18**(4): 241-252 (1993).
- [15] V. G. W. Harrison, *Definition and measurement of gloss: a survey of published literature*, Printing and Allied Trades Research Association, Cambridge, 1945.
- [16] F. W. Campbell and L. Maffei, Contrast and Spatial Frequency, *Scientific American* **231**(5): 106-114 (1974).
- [17] O. R. Mitchell, Effect of spatial frequency on the visibility of unstructured patterns, *J. Opt. Soc. Am.* **66**(4): 327-332 (1976). <http://dx.doi.org/10.1364/JOSA.66.000327>.
- [18] R. M. Leekley, C. W. Denzer, and R. F. Tyler, Measurement of Surface Reflection From Papers and Prints, *TAPPI* **53**(4): 615-621 (1970).
- [19] I. M. Lancaster and A. Mitchell, The growth of optically variable features on banknotes, *Optical Security and Counterfeit Deterrence Techniques V*, Vol. 5310, pp. 34-45, San Jose, CA, USA, 2004, (SPIE), 2004. <http://dx.doi.org/10.1117/12.549893>.
- [20] H. I. Bjelkhagen, patent US 5,972,546 (1999).
- [21] H. I. Bjelkhagen, A new OVD based on interferential photography recorded in holographic materials, *Holographic Materials V, Electronic Imaging*, Vol. 3638, pp. 87-95, San José, CA, USA, 23 March, 1999, (SPIE). <http://dx.doi.org/10.1117/12.342808>.
- [22] H. I. Bjelkhagen, New optical security device based on one-hundred-year-old photographic technique, *Opt. Eng.* **38**(1): 55-61 (1999). <http://dx.doi.org/10.1117/1.602061>.
- [23] H. I. Bjelkhagen, The Lippmann OVD for enhanced document security, *Optical Security and Counterfeit Deterrence Techniques III*, Vol. 3973, pp. 276-283, San Jose, CA, USA, 7 April, 2000, (SPIE), 2000. <http://dx.doi.org/10.1117/12.382198>.

- [24] R. L. van Renesse, What is "funny" about Funny Money?, in *Keesing Journal of Documents & Identity*, pp. 3-9, 2006.
- [25] Security features of the U.S. \$100 Note, Issued 2013, (The U.S. Currency Education Program, 2013). <https://www.uscurrency.gov/security/100-security-features-2013-present>, accessed 30 August 2018.
- [26] P. Lalonde and A. Fournier, A Wavelet Representation of Reflectance Functions, *IEEE Transactions on visualization and computer graphics* **3**(4): 329-336 (1997).
- [27] K. J. Dana, B. v. Ginneken, S. K. Nayar et al., Reflectance and Texture of Real-World Surfaces, *IEEE Computer Society Conference on Computer Vision and Pattern Recognition*, pp. 151-157, San Juan, Puerto Rico, 1997, (IEEE Computer Society).
- [28] W. Li, P. Ogunbona, Y. Shi et al., Modelling of color cross-talk in CMOS image sensors, *IEEE International Conference on Acoustics, Speech, and Signal Processing (ICASSP)*, pp. 3576–3579, Orlando, FL, USA, 13–17 May, 2002, (IEEE), 2002. <http://dx.doi.org/10.1109/icassp.2002.5745428>.
- [29] G. Agranov, V. Berezin, and R. H. Tsai, Crosstalk and Microlens Study in a Color CMOS Image Sensor, *IEEE Trans. Electron Devices* **50**(1): 4–11 (2003). <http://dx.doi.org/10.1109/ted.2002.806473>.
- [30] A. Getman, T. Uvarov, Y. I. Han et al., Crosstalk, color tint and shading correction for small pixel size image sensor, *International Image Sensor Workshop*, pp. 166–169, Ogunquit, ME, USA, 7–10 June, 2007, 2007. <http://www.imagesensors.org/Past%20Workshops/2007%20Workshop/2007%20Papers/042%20Getman%20et%20al.pdf>, accessed 30 August 2018.
- [31] P. Beckmann and A. Spizzichino, *The Scattering of Electromagnetic Waves from Rough Surfaces*, Pergamon Press, New York, 1963.
- [32] K. E. Torrance and E. M. Sparrow, Theory for Off-Specular Reflection From Roughened Surfaces, *J. Opt. Soc. Am.* **57**(9): 1105-1114 (1967). <http://dx.doi.org/10.1364/JOSA.57.001105>.
- [33] S. K. Nayar and T. Kanade, Surface Reflection: Physical and Geometrical Perspectives, *IEEE Trans. Pattern Anal. Mach. Intell.* **13**(7): 611-634 (1991).
- [34] J. M. Fetsko, F. E. Witherell, and G. W. Poehlein, Relationship between gloss and surface roughness of paperboard samples and prints, *Advances in printing science and technology*, Vol. 12, pp. 67-72, Versailles, France, June, 1973, (IPC Science and Technology Press, Guildford, UK).

Bibliography

- [35] J. M. Fetsko and A. C. Zettlemoyer, Factors Affecting Print Gloss and Uniformity, *TAPPI Journal* **45**(8): 667-681 (1962).
- [36] A. Paul, Measuring technology for assessing gloss, *Professional Printer* **38**(2): 13-16 (1994).
- [37] M.-C. Béland, S. Lindberg, and P.-Å. Johansson, Optical Measurement and Perception of Gloss Quality of Printed Matte-Coated Paper, *Journal of Pulp and Paper Science* **26**(3): 120-123 (2000).
- [38] P. Bouguer, *Traité d'optique sur la gradation de la lumiere (Ouvrage posthume de M. Bouguer)*, M. l'Abbé De La Caille, Paris, 1760.
- [39] P. Bouguer, *Optical treatise on the gradation of light* (English translation with introduction and notes by W. E. Knowles Middleton.), University of Toronto Press, Toronto, 1961.
- [40] W. R. Hendee and P. N. T. Wells, *The Perception of Visual Information*, Springer, New York, NY, USA, 1997. <http://dx.doi.org/10.1007/978-1-4612-1836-4>.
- [41] B. E. Rogowitz and H. E. Rushmeier, Are Image Quality Metrics Adequate to Evaluate the Quality of Geometric Objects?, *SPIE Human Vision and Electronic Imaging 2001*, Vol. 4299, pp. 340-348, San José, CA, 2001, (SPIE).
- [42] W. A. Ijsselsteijn, H. de Ridder, J. Freeman et al., Presence: Concept, determinants and measurement, *SPIE Human Vision and Electronic Imaging 2000*, Vol. 3959, pp. 520-529, San José, CA, 2000, (SPIE).
- [43] *A Path to the Next Generation of U.S. Banknotes: Keeping Them Real*, National Research Council, The National Academies Press, Washington, DC, 2007. <http://dx.doi.org/10.17226/11874>.
- [44] I. M. Lancaster, Use and efficacy of DOVIDs and other optical security devices, *Optical Security and Counterfeit Deterrence Techniques VI*, Vol. 6075, pp. 607500, San Jose, CA, USA, 2006, (SPIE), 2006. <http://dx.doi.org/10.1117/12.648416>.
- [45] D. A. Norman, *The design of everyday things*, Basic Books, New York, DC, USA, 2013.
- [46] ICAO, 978-92-9249-791-0:2015, Doc 9303, Machine Readable Travel Documents; Part 2 — Specifications for the Security of the Design, Manufacture and Issuance of MRTDs, ICAO, Montréal, Quebec, Canada.

- https://www.icao.int/publications/Documents/9303_p2_cons_en.pdf, accessed 30 August 2018.
- [47] EU Council, 2004, REGULATION (EC) No 2252/2004 on standards for security features and biometrics in passports and travel documents issued by Member States. <http://eur-lex.europa.eu/legal-content/EN/TXT/?uri=CELEX:32004R2252>, accessed 30 August 2018.
- [48] R. S. Pappu, Physical one-way functions, PhD Dissertation, Massachusetts Institute of Technology, 2001. <http://hdl.handle.net/1721.1/45499>, accessed 30 August 2018.
- [49] R. Pappu, B. Recht, J. Taylor et al., Physical One-Way Functions, *Science* **297**(5589): 2026-2030 (2002). <http://dx.doi.org/10.1126/science.1074376>.
- [50] R. Maes, *Physically unclonable functions: constructions, properties and applications*, Springer Berlin Heidelberg, 2013. <http://dx.doi.org/10.1007/978-3-642-41395-7>.
- [51] J. L. Danger, S. Guilley, P. Nguyen et al., PUFs: Standardization and Evaluation, *Mobile Systems Technologies Workshop: Architecture, Technology Trends, and Memory Solutions, (MST)*, pp. 12-18, Milan, Italy, 23-23 September, 2016, (IEEE). <http://dx.doi.org/10.1109/mst.2016.11>.
- [52] F. Armknecht, D. Moriyama, A.-R. Sadeghi et al., Towards a Unified Security Model for Physically Unclonable Functions, *Topics in Cryptology - CT-RSA: The Cryptographers' Track at the RSA Conference*, pp. 271-287, San Francisco, CA, USA, February 29 - March 4, 2016, (Springer Cham). http://dx.doi.org/10.1007/978-3-319-29485-8_16.
- [53] H. A. M. de Heij, Programme of Requirements: a powerful tool to develop new, secure banknotes, *Optical Document Security - The Conference on Optical Security and Counterfeit Deterrence*, San Francisco, January 23-25, 2008, (Reconnaissance International).
- [54] R. L. van Renesse, GonioLabs' Novel DOVID Reader, in *Holography News*, Vol. 22, pp. 4-5, 2008.
- [55] R. L. van Renesse, Testing the Universal Hologram Scanner, in *Keesing Journal of Documents & Identity*, pp. 7-10, 2005.
- [56] M. Mohammadi, Developing an Imaging Bi-Spectrometer for Fluorescent Materials, Rochester Institute of Technology, 2009. <http://scholarworks.rit.edu/theses/4564/>, accessed 30 August 2018.

Papers

The papers associated with this thesis have been removed for copyright reasons. For more details about these see:

<http://urn.kb.se/resolve?urn=urn:nbn:se:liu:diva-151626>